

Technical Specification code: GRI-GRI-MAT-E&C-0002

Version no.3 dated 03/10/2022

Subject: Enel Grids - GSM001 - Medium Voltage Gas Insulated Switchgears for secondary distribution substations

Application Areas

Perimeter: Global

Staff Function: -

Service Function: -

Business Line: Enel Grids

CONTENTS

1	DOCUMENT AIMS AND APPLICATION AREA	4
1.1	RELATED DOCUMENTS TO BE IMPLEMENTED AT COUNTRY LEVEL	5
2	DOCUMENT VERSION MANAGEMENT	5
3	UNITS IN CHARGE OF THE DOCUMENT	5
4	REFERENCES	6
4.1	INTERNATIONAL STANDARDS.....	6
4.2	APPLICABLE LAWS AND REFERENCE STANDARDS	8
4.2.1	Reference Laws.....	8
4.2.2	Enel Grid Technical Standards.....	8
4.2.3	Colombian Technical Standards.....	8
5	ORGANIZATIONAL PROCESS POSITION IN THE PROCESS TAXONOMY	9
6	DEFINITIONS AND ACRONYMS.....	10
7	DESCRIPTION	11
7.1	LIST OF COMPONENTS	11
7.2	SERVICE CONDITIONS	17
7.3	TECHNICAL CHARACTERISTICS.....	18
7.3.1	Switchgear characteristics.....	18
7.3.2	Rated characteristics	20
7.3.3	Functional Unit Schemes.....	21
7.3.4	Line Functional Unit (L)	23
7.3.5	Transformer Protection Functional Unit (T)	30
7.3.6	Manometer.....	43
7.3.7	Earth connections	43
7.3.8	Design requirement for installation	44
7.3.9	Cable compartments	44
7.3.10	Voltage detecting systems.....	46



Technical Specification code: GRI-GRI-MAT-E&C-0002

Version no.3 dated 03/10/2022

Subject: Enel Grids - GSM001 - Medium Voltage Gas Insulated Switchgears for secondary distribution substations

Application Areas

Perimeter: Global

Staff Function: -

Service Function: -

Business Line: Enel Grids

7.3.11	Low Power voltage Transformers.....	47
7.3.12	Support for the fault detector device (RGDM/RGDAT) and cable duct.....	47
7.3.13	Command lever	48
7.3.14	Switchgear dimensions.....	48
7.3.15	Modular MV switchgears	49
7.3.16	Compact modules 5L+1T	50
7.3.17	Protective coating	50
7.3.18	Nameplates.....	51
7.3.19	Maintenance	53
7.3.20	Packaging, handling and impact indicators (Shockwatch)	53
7.4	TESTING	54
7.4.1	Type tests	55
7.4.2	Routine tests.....	59
7.4.3	Factory acceptance tests.....	60
7.5	SUPPLY REQUIREMENTS	63
7.6	INTERLOCKS CHECKING.....	65
7.7	CHARACTERISTICS OF THE ELECTRICAL COMMAND.....	66
7.7.1	Electric motor.....	66
7.7.2	Electric command of the switch-disconnector	66
7.7.3	Connections.....	67
7.7.4	Connectors	67
7.7.5	Wiring.....	69
7.8	MV RMU "AUX" UNIT	72
7.8.1	Application field.....	73
7.8.2	General Characterstic.....	73

Technical Specification code: GRI-GRI-MAT-E&C-0002

Version no.3 dated 03/10/2022

Subject: Enel Grids - GSM001 - Medium Voltage Gas Insulated Switchgears for secondary distribution substations

Application Areas

Perimeter: Global

Staff Function: -

Service Function: -

Business Line: Enel Grids

7.8.3	Transformer protection unit	74
7.8.4	Voltage transformer (VT)	76
7.8.5	Auxiliary services protection module.	78
7.8.6	Auxiliary services connection module.....	81
7.8.7	Ferroresonance damping resistor.....	84
7.8.8	Wiring diagram of the "AUX UNIT"	86
7.8.9	Tests.....	88
7.9	Busbar VDS Constructive characteristics.....	91
7.9.1	Electrical construction characteristics:	92
7.9.2	Testing.....	93
ANNEX A – TECHNICAL CHECK-LIST FOR TENDER PROCESS.....		95

THE HEAD OF NETWORK COMPONENTS
Fabrizio Gasbarri

Technical Specification code: GRI-GRI-MAT-E&C-0002

Version no.3 dated 03/10/2022

Subject: Enel Grids - GSM001 - Medium Voltage Gas Insulated Switchgears for secondary distribution substations

Application Areas

Perimeter: Global

Staff Function: -

Service Function: -

Business Line: Enel Grids

1 DOCUMENT AIMS AND APPLICATION AREA

The scope of this document is to provide the technical requirements for Medium Voltage (MV) Gas-Insulated switchgears (GIS), with rated voltage 24 kV and 36 kV to be installed as indoor equipment in *Secondary Distribution Substations* of the Enel Grids Distribution Companies listed below:

Country	Distribution Company
Argentina	Edesur
Brazil	Enel Distribuição Rio Enel Distribuição Ceará Enel Distribuição Goiás Enel Distribuição São Paulo
Chile	Enel Distribución Chile
Colombia	Enel Codensa
Iberia	e-distribución
Italy	e-distribuzione
Peru	Enel Distribución Perú
Romania	Enel Distribuție Banat Enel Distribuție Dobrogea Enel Distribuție Muntenia

Table 1 - Distribution Companies

This document shall be implemented and applied to the extent possible within the Enel Grids Business Line and in compliance with any applicable laws, regulations and governance rules, including any stock exchange and unbundling-relevant provisions, which in any case prevail over the provisions contained in this document.

Technical Specification code: GRI-GRI-MAT-E&C-0002

Version no.3 dated 03/10/2022

Subject: Enel Grids - GSM001 - Medium Voltage Gas Insulated Switchgears for secondary distribution substations

Application Areas

Perimeter: Global

Staff Function: -

Service Function: -

Business Line: Enel Grids

1.1 RELATED DOCUMENTS TO BE IMPLEMENTED AT COUNTRY LEVEL

This document does not require implementation of further documents. Anyway, each Enel Grids Company can issue, under the supervision of Enel Grids Global Network Components detailed documents, according to the provisions of the present document and in case of specific needs.

2 DOCUMENT VERSION MANAGEMENT

Version	Date	Main changes description
0	10/07/2014	First emission
1	30/11/2020	Rated short-circuit duration - Rated arc fault duration – VDS- Directions of operation of switch-disconnector and earthing switches – Only motorized switchgear - LPVT embedded
2	08/07/2021	Release of “Global Infrastructure and Networks – GSM001 vers.2. Standardized format release, editorial errors correction.
3	03/10/2022	Subject updated. SF6 alternatives are accepted. Editorial corrections. Internal arc test clarification. VDIS alternative is introduced. Type test list update. Routine test redefinition according to Enel QCM indications. Harmonization and reduction of type codes. Introduced busbar VDS design and construction characteristics. Transformer functional unit with circuit breaker is included. Cable connection to RTU excluded from the supply.
3	04/01/2023	Errata corrige GSM001 rev.3
3	24/06/2024	Errata corrige2 GSM001 rev.3

3 UNITS IN CHARGE OF THE DOCUMENT

Responsible for drawing up the document:

- Enel Grids: Engineering and Construction /Components and Devices Design/ Network Components/ MV and LV Equipment unit

Responsible for authorizing the document:

- Enel Grids: Head of Network Components unit
- Enel Grids: Head of Quality unit.



Technical Specification code: GRI-GRI-MAT-E&C-0002

Version no.3 dated 03/10/2022

Subject: Enel Grids - GSM001 - Medium Voltage Gas Insulated Switchgears for secondary distribution substations

Application Areas

Perimeter: Global

Staff Function: -

Service Function: -

Business Line: Enel Grids

4 REFERENCES

- Code of Ethics of Enel Group;
- Enel Human Right Policy;
- The Enel Group Zero Tolerance of Corruption (ZTC) Plan;
- Organization and management model as per Legislative Decree No. 231/2001;
- Enel Global Compliance Program (EGCP);
- Integrated Policy for Quality, Health and Safety, Environment, anti-Bribery and Information security;
- ISO 9001:2015 - Quality Management System – Requirements;
- ISO 14001:2015 - Environmental Management System - Requirements with guidance for use;
- ISO 45001:2018 - Occupational Health and Safety Management System - Requirements with guidance for use;
- ISO 37001:2016 - Anti-bribery Management System - Requirements with guidance for use;
- ISO 27001:2017 - Information Security Management System – Requirements.

4.1 INTERNATIONAL STANDARDS

The listed reference documents shall be intended in the in-force edition at the TCA date (amendments and errata included). Unless otherwise specified, these documents are valid until the new editions:

- EN 50181 Plug-in type bushings above 1 kV up to 52 kV and from 250 A to 2,50 kA for equipment other than liquid filled transformers
- EN 60282-1 High-voltage fuses - Part 1: Current-limiting fuses
- EN 61439-2 High-voltage fuses - Part 1: Current-limiting fuses
- EN 61869-1-3 Instrument transformers - Part 1-3
- EN 62262 Degrees of protection provided by enclosures for electrical equipment against external mechanical impacts (IK Code)
- IEC 60068-2-52 Environmental testing – Part 2-52: Tests – Test Kb: Salt mist, cyclic (sodium chloride solution).
- IEC 60137 Insulated bushings for alternating voltages above 1000 V
- IEC 60282-1 High-voltage fuses - Part 1: Current-limiting fuses.

Technical Specification code: GRI-GRI-MAT-E&C-0002

Version no.3 dated 03/10/2022

Subject: Enel Grids - GSM001 - Medium Voltage Gas Insulated Switchgears for secondary distribution substations

Application Areas

Perimeter: Global

Staff Function: -

Service Function: -

Business Line: Enel Grids

- IEC 60447 Basic and safety principles for man-machine interface, marking and identification - Actuating principles.
- IEC 60529 Degrees of protection provided by enclosures (IP Code).
- IEC 61243-5 Live working - Voltage detectors - Part 5: Voltage detecting systems (VDS).
- IEC 62271-1 High-voltage switchgear and controlgear - Part 1: Common specifications for alternating current switchgear and controlgear.
- IEC 62271-102 High-voltage switchgear and controlgear - Part 102: Alternating current disconnectors and earthing switches.
- IEC 62271-103 High-voltage switchgear and controlgear - Part 103: Switches for rated voltages above 1 kV up to and including 52 kV.
- IEC 62271-105 High-voltage switchgear and controlgear - Part 105: Alternating current switch-fuse combinations for rated voltages above 1 kV up to and including 52 kV.
- IEC 62271-200 High-voltage switchgear and controlgear - Part 200: AC metal-enclosed switchgear and controlgear for rated voltages above 1 kV and up to and including 52 kV.
- IEC TS 62271-210 High-voltage switchgear and controlgear - Part 210: Seismic qualification for metal enclosed and solid-insulation enclosed switchgear and controlgear assemblies for rated voltages above 1 kV and up to and including 52 kV.
- ISO 12944 Paints and varnishes — Corrosion protection of steel structures by protective paint systems.
- ISO 2409 Paints and varnishes — Cross-cut test.
- ISO 4042 Fasteners - Electroplated coatings
- ISO/IEC 17000 Conformity assessment – Vocabulary and general principles
- ISO/IEC 17020 General criteria for the operation of various types of bodies performing inspection
- ISO/IEC 17025 General requirements for the competence of testing and calibration laboratories
- ISO/IEC 17050-1 Conformity assessment - Supplier's declaration of conformity - Part 1: General requirements (ISO/IEC 17050-1:2004, corrected version 2007-06-15)
- ISO/IEC 17050-2 Conformity assessment - Supplier's declaration of conformity - Part 2: Supporting documentation (ISO/IEC 17050-2:2004)



Technical Specification code: GRI-GRI-MAT-E&C-0002

Version no.3 dated 03/10/2022

Subject: Enel Grids - GSM001 - Medium Voltage Gas Insulated Switchgears for secondary distribution substations

Application Areas

Perimeter: Global

Staff Function: -

Service Function: -

Business Line: Enel Grids

- ISO/IEC 17065 Conformity assessment – Requirements for bodies certifying products, processes, and services

4.2 APPLICABLE LAWS AND REFERENCE STANDARDS

4.2.1 Reference Laws

4.2.1.1 Colombia

The switchgear shall comply with the requirements established in the “Anexo General del RETIE Resolución 9 0708 de Agosto 30 de 2013 con sus Ajustes” and demonstrate this by means of a Certificate of Product Conformity.

4.2.1.2 Spain

The switchgear shall comply with the “Reglamento sobre condiciones técnicas y garantías de seguridad en instalaciones eléctricas de alta tensión y sus Instrucciones Técnicas Complementarias ITC-RAT 01 a 23 (R.D. 337/2014, de 9 de mayo)”, and consequently each switchgear shall be supplied accompanied by the "Declaración de Conformidad " required by this regulation, and the manufacturer or his authorized representative established in the European Union must keep the required “Expediente técnico” at disposal of the Spanish national market surveillance authority for inspection up to at least five years from the last date of manufacture of the product.

DND001 Ed.7 Cables aislados para redes aéreas y subterráneas de media tensión hasta 30kV

4.2.2 Enel Grid Technical Standards

- GSCC006 12/20(24) kV and 18/30(36) kV Separable connectors for MV cables.
- GSCT005 Technical characteristics of LPITs for RGDM/RGDAT.
- GSC001 Medium voltage cables with rated voltage $U_o/U_c(U_m)$ 8,7/15(17,5) kV, 12/20(24) kV, 15/25(31) kV, 18/30(36) kV and 20/34,5(37,95) kV.
- CNS-O&M-S&L-2021-0032-EGIN Global Infrastructure and Networks Barcode specification

4.2.3 Colombian Technical Standards

- NSR-10 Requisitos generales de diseño y construcción sismo resistente.



Technical Specification code: GRI-GRI-MAT-E&C-0002

Version no.3 dated 03/10/2022

Subject: Enel Grids - GSM001 - Medium Voltage Gas Insulated Switchgears for secondary distribution substations

Application Areas

Perimeter: Global

Staff Function: -

Service Function: -

Business Line: Enel Grids

5 ORGANIZATIONAL PROCESS POSITION IN THE PROCESS TAXONOMY

- Value Chain/Process Area: Engineering and Construction
- Macro Process: Devices and Components Development
- Process: Standard Catalog Management

Technical Specification code: GRI-GRI-MAT-E&C-0002

Version no.3 dated 03/10/2022

Subject: Enel Grids - GSM001 - Medium Voltage Gas Insulated Switchgears for secondary distribution substations

Application Areas

Perimeter: Global

Staff Function: -

Service Function: -

Business Line: Enel Grids

6 DEFINITIONS AND ACRONYMS

Acronym and Key words	Description
Gas Insulated Switchgear (GIS)	A general term covering switching devices and their combination with associated control, measuring, protective and regulating equipment, also assemblies of such devices and equipment with associated interconnections, accessories, enclosures and supporting structures, intended in principle for use in connection with generation, transmission, distribution and conversion of electric energy, with Gas insulation
Low Voltage (LV)	Any set of nominal voltage levels exceeding 50 V and up to 1 kV a.c. or 1,5 kV d.c.
Medium Voltage (MV)	System with a nominal operative voltage between the phases higher than 1 kV to 35 kV included. NOTE: The boundary value between medium voltage and high voltage depends on local and historical circumstances or on common usage. Nevertheless for internal standardization purposes, medium voltage is defined as a system with a nominal operative voltage between the phases higher than 1 kV to 35 kV included"
Technical Conformity Assessment (TCA)	A "conformity assessment with respect to "specified requirements" consists in functional, dimensional, constructional and test characteristics required for a product (or a series of products) and quoted in technical specifications and quality requirements issued by Enel Group distribution companies. This also includes the verification of conformity with respect to local applicable regulation and laws and possession of relevant requested certifications
Type A documentation	Not confidential documents used for product manufacturing and management from which it is possible to verify the product conformity to all technical specification requirements, directly or indirectly
TCA report	Document describing the activities carried out for TCA
TCA dossier	Set of final documents delivered by the Supplier for the TCA



Technical Specification code: GRI-GRI-MAT-E&C-0002

Version no.3 dated 03/10/2022

Subject: Enel Grids - GSM001 - Medium Voltage Gas Insulated Switchgears for secondary distribution substations

Application Areas

Perimeter: Global

Staff Function: -

Service Function: -

Business Line: Enel Grids

7 DESCRIPTION

7.1 LIST OF COMPONENTS

Type code	Configuration	GS technology	Distribution Company and Contry	Country Code	Rated frequency fr [Hz]	Rated normal current I _n [A]	Rated Voltage U _r [kV]	Rated power-frequency withstand voltage U _a [kV]	Rated lightning impulse withstand voltage U _p [kV]	Rated short-time withstand current I _k [kA]	Rated duration of short circuit t _k [s]	Rated peak withstand current I _p [kA]	Rated supply voltage of closing and opening devices and of auxiliary circuit V _{cc}	IK degree	IP degree	SD - Mechanical endurance class- Electrical endurance class	ES - Mechanical endurance class- Electrical endurance class	Classification IAC	Arc fault current and duration I _a (kA); t _a (s)	Protective Coating	Command Type	Busbar Socket	Description
GSM001/1	2L+1T	SF6	ED-Italy	162116	50 and 60	630	24	50	125	16	1	41,6	24V -15% +20%	IK08	IP3X	M1 - E3	M0 - E2	AFL	16; 1	C3H	Electrical	Yes	MV Switchgear 2L+1T SF6 24 kV 16 kA AFL IP3X C3H GSM001/1
GSM001/1	2L+1T	SF6 FREE	ED-Italy	140117	50 and 60	630	24	50	125	16	1	41,6	24V -15% +20%	IK08	IP3X	M1 - E3	M0 - E2	AFL	16; 1	C3H	Electrical	Yes	MV Switchgear 2L+1T SF6 FREE 24 kV 16 kA AFL IP3X C3H GSM001/1
GSM001/1	2L+1T	SF6	ED-Chile	140275	50 and 60	630	24	50	125	16	1	41,6	24V -15% +20%	IK08	IP3X	M1 - E3	M0 - E2	AFL	16; 1	C3H	Electrical	Yes	MV Switchgear 2L+1T SF6 24 kV 16 kA AFL IP3X C3H GSM001/1
GSM001/1	2L+1T	SF6	ED-Colombia	140401	50 and 60	630	24	50	125	16	1	41,6	24V -15% +20%	IK08	IP3X	M1 - E3	M0 - E2	AFL	16; 1	C3H	Electrical	Yes	MV Switchgear 2L+1T SF6 24 kV 16 kA AFL IP3X C3H GSM001/1
GSM001/1	2L+1T	SF6 FREE	ED-Colombia	140596	50 and 60	630	24	50	125	16	1	41,6	24V -15% +20%	IK08	IP3X	M1 - E3	M0 - E2	AFL	16; 1	C3H	Electrical	Yes	MV Switchgear 2L+1T SF6 FREE 24 kV 16 kA AFL IP3X C3H GSM001/1
GSM001/1	2L+1T	SF6	ED-Romania	140042	50 and 60	630	24	50	125	16	1	41,6	24V -15% +20%	IK08	IP3X	M1 - E3	M0 - E2	AFL	16; 1	C3H	Electrical	Yes	MV Switchgear 2L+1T SF6 24 kV 16 kA AFL IP3X C3H GSM001/1
GSM001/1	2L+1T	SF6 FREE	ED-Romania	140117	50 and 60	630	24	50	125	16	1	41,6	24V -15% +20%	IK08	IP3X	M1 - E3	M0 - E2	AFL	16; 1	C3H	Electrical	Yes	MV Switchgear 2L+1T SF6 FREE 24 kV 16 kA AFL IP3X C3H GSM001/1
GSM001/1	2L+1T	SF6	ED-Spain	140224	50 and 60	630	24	50	125	16	1	41,6	24V -15% +20%	IK08	IP3X	M1 - E3	M0 - E2	AFL	16; 1	C3H	Electrical	No	MV Switchgear 2L+1T SF6 24 kV 16 kA AFL IP3X C3H GSM001/1
GSM001/1	2L+1T	SF6 FREE	ED-Spain	140806	50 and 60	630	24	50	125	16	1	41,6	24V -15% +20%	IK08	IP3X	M1 - E3	M0 - E2	AFL	16; 1	C3H	Electrical	No	MV Switchgear 2L+1T SF6 FREE 24 kV 16 kA AFL IP3X C3H GSM001/1
GSM001/1	2L+1T	SF6	ED-Brazil	141183	50 and 60	630	24	50	125	16	1	41,6	24V -15% +20%	IK08	IP3X	M1 - E3	M0 - E2	AFL	16; 1	C3H	Electrical	Yes	MV Switchgear 2L+1T SF6 24 kV 16 kA AFL IP3X C3H GSM001/1
GSM001/1	2L+1T	SF6 FREE	ED-Brazil	140828	50 and 60	630	24	50	125	16	1	41,6	24V -15% +20%	IK08	IP3X	M1 - E3	M0 - E2	AFL	16; 1	C3H	Electrical	Yes	MV Switchgear 2L+1T SF6 FREE 24 kV 16 kA AFL IP3X C3H GSM001/1
GSM001/1	2L+1T	SF6	ED-Argentina	0109-0492	50 and 60	630	24	50	125	16	1	41,6	24V -15% +20%	IK08	IP3X	M1 - E3	M0 - E2	AFL	16; 1	C3H	Electrical	Yes	MV Switchgear 2L+1T SF6 24 kV 16 kA AFL IP3X C3H GSM001/1
GSM001/1	2L+1T	SF6 FREE	ED-Argentina	0109-0499	50 and 60	630	24	50	125	16	1	41,6	24V -15% +20%	IK08	IP3X	M1 - E3	M0 - E2	AFL	16; 1	C3H	Electrical	Yes	MV Switchgear 2L+1T SF6 FREE 24 kV 16 kA AFL IP3X C3H GSM001/1
GSM001/1	2L+1T	SF6 FREE	ED-Chile	141201	50 and 60	630	24	50	125	16	1	41,6	24V -15% +20%	IK08	IP3X	M1 - E3	M0 - E2	AFL	16; 1	C3H	Electrical	Yes	MV Switchgear 2L+1T SF6 FREE 24 kV 16 kA AFL IP3X C3H GSM001/1
GSM001/2	3L+1T	SF6 FREE	ED-Argentina	0109-0500	50 and 60	630	24	50	125	16	1	41,6	24V -15% +20%	IK08	IP3X	M1 - E3	M0 - E2	AFL	16; 1	C3H	Electrical	Yes	MV Switchgear 3L+1T SF6 FREE 24 kV 16 kA AFL IP3X C3H GSM001/2
GSM001/2	3L+1T	SF6	ED-Argentina	0109-0493	50 and 60	630	24	50	125	16	1	41,6	24V -15% +20%	IK08	IP3X	M1 - E3	M0 - E2	AFL	16; 1	C3H	Electrical	Yes	MV Switchgear 3L+1T SF6 24 kV 16 kA AFL IP3X C3H GSM001/2
GSM001/2	3L+1T	SF6	ED-Italy	162117	50 and 60	630	24	50	125	16	1	41,6	24V -15% +20%	IK08	IP3X	M1 - E3	M0 - E2	AFL	16; 1	C3H	Electrical	Yes	MV Switchgear 3L+1T SF6 24 kV 16 kA AFL IP3X C3H GSM001/2
GSM001/2	3L+1T	SF6 FREE	ED-Italy	140318	50 and 60	630	24	50	125	16	1	41,6	24V -15% +20%	IK08	IP3X	M1 - E3	M0 - E2	AFL	16; 1	C3H	Electrical	Yes	MV Switchgear 3L+1T SF6 FREE 24 kV 16 kA AFL IP3X C3H GSM001/2
GSM001/2	3L+1T	SF6	ED-Colombia	140402	50 and 60	630	24	50	125	16	1	41,6	24V -15% +20%	IK08	IP3X	M1 - E3	M0 - E2	AFL	16; 1	C3H	Electrical	Yes	MV Switchgear 3L+1T SF6 24 kV 16 kA AFL IP3X C3H GSM001/2
GSM001/2	3L+1T	SF6	ED-Romania	140043	50 and 60	630	24	50	125	16	1	41,6	24V -15% +20%	IK08	IP3X	M1 - E3	M0 - E2	AFL	16; 1	C3H	Electrical	Yes	MV Switchgear 3L+1T SF6 24 kV 16 kA AFL IP3X C3H GSM001/2
GSM001/2	3L+1T	SF6 FREE	ED-Romania	140318	50 and 60	630	24	50	125	16	1	41,6	24V -15% +20%	IK08	IP3X	M1 - E3	M0 - E2	AFL	16; 1	C3H	Electrical	Yes	MV Switchgear 3L+1T SF6 FREE 24 kV 16 kA AFL IP3X C3H GSM001/2
GSM001/2	3L+1T	SF6	ED-Spain	140226	50 and 60	630	24	50	125	16	1	41,6	24V -15% +20%	IK08	IP3X	M1 - E3	M0 - E2	AFL	16; 1	C3H	Electrical	No	MV Switchgear 3L+1T SF6 24 kV 16 kA AFL IP3X C3H GSM001/2
GSM001/2	3L+1T	SF6 FREE	ED-Spain	140827	50 and 60	630	24	50	125	16	1	41,6	24V -15% +20%	IK08	IP3X	M1 - E3	M0 - E2	AFL	16; 1	C3H	Electrical	No	MV Switchgear 3L+1T SF6 FREE 24 kV 16 kA AFL IP3X C3H GSM001/2
GSM001/2	3L+1T	SF6	ED-Brazil	141186	50 and 60	630	24	50	125	16	1	41,6	24V -15% +20%	IK08	IP3X	M1 - E3	M0 - E2	AFL	16; 1	C3H	Electrical	Yes	MV Switchgear 3L+1T SF6 24 kV 16 kA AFL IP3X C3H GSM001/2
GSM001/2	3L+1T	SF6 FREE	ED-Brazil	140827	50 and 60	630	24	50	125	16	1	41,6	24V -15% +20%	IK08	IP3X	M1 - E3	M0 - E2	AFL	16; 1	C3H	Electrical	Yes	MV Switchgear 3L+1T SF6 FREE 24 kV 16 kA AFL IP3X C3H GSM001/2
GSM001/2	3L+1T	SF6 FREE	ED-Colombia	140770	50 and 60	630	24	50	125	16	1	41,6	24V -15% +20%	IK08	IP3X	M1 - E3	M0 - E2	AFL	16; 1	C3H	Electrical	Yes	MV Switchgear 3L+1T SF6 FREE 24 kV 16 kA AFL IP3X C3H GSM001/2
GSM001/2	3L+1T	SF6	ED-Chile	141195	50 and 60	630	24	50	125	16	1	41,6	24V -15% +20%	IK08	IP3X	M1 - E3	M0 - E2	AFL	16; 1	C3H	Electrical	Yes	MV Switchgear 3L+1T SF6 24 kV 16 kA AFL IP3X C3H GSM001/2

Technical Specification code: GRI-GRI-MAT-E&C-0002

Version no.3 dated 03/10/2022

Subject: Enel Grids - GSM001 - Medium Voltage Gas Insulated Switchgears for secondary distribution substations

Application Areas

Perimeter: Global

Staff Function: -

Service Function: -

Business Line: Enel Grids

Type code	Configuration	GIS technology	Distribution Company and Contry	Country Code	Rated frequency fr [Hz]	Rated normal current I _n [A]	Rated Voltage U _r [kV]	Rated power-frequency withstand voltage U _d [kV]	Rated lightning impulse withstand voltage U _p [kV]	Rated short-time withstand current I _k [kA]	Rated duration of short circuit t _k [s]	Rated peak withstand current I _p [kA]	Rated supply voltage of closing and opening devices and of auxiliary circuit V _{cc}	IK degree	IP degree	SD - Mechanical endurance class- Electrical endurance class	ES - Mechanical endurance class- Electrical endurance class	Classification IAC	Arc fault current and duration I _k (kA); t _k (s)	Protective Coating	Command Type	Busbar Socket	Description
GSM001/3	3L	SF6	ED-Italy	162118	50 and 60	630	24	50	125	16	1	41,6	24V -15% +20%	IK08	IP3X	M1 - E3	M0 - E2	AFL	16; 1	C3H	Electrical	Yes	MV Switchgear 3LSF6 24 kV 16 kA AFL IP3X C3H GSM001/3
GSM001/3	3L	SF6 FREE	ED-Italy	140319	50 and 60	630	24	50	125	16	1	41,6	24V -15% +20%	IK08	IP3X	M1 - E3	M0 - E2	AFL	16; 1	C3H	Electrical	Yes	MV Switchgear 3LSF6 FREE 24 kV 16 kA AFL IP3X C3H GSM001/3
GSM001/3	3L	SF6	ED-Chile	140276	50 and 60	630	24	50	125	16	1	41,6	24V -15% +20%	IK08	IP3X	M1 - E3	M0 - E2	AFL	16; 1	C3H	Electrical	Yes	MV Switchgear 3LSF6 24 kV 16 kA AFL IP3X C3H GSM001/3
GSM001/3	3L	SF6	ED-Colombia	140403	50 and 60	630	24	50	125	16	1	41,6	24V -15% +20%	IK08	IP3X	M1 - E3	M0 - E2	AFL	16; 1	C3H	Electrical	Yes	MV Switchgear 3LSF6 24 kV 16 kA AFL IP3X C3H GSM001/3
GSM001/3	3L	SF6	ED-Romania	140044	50 and 60	630	24	50	125	16	1	41,6	24V -15% +20%	IK08	IP3X	M1 - E3	M0 - E2	AFL	16; 1	C3H	Electrical	Yes	MV Switchgear 3LSF6 24 kV 16 kA AFL IP3X C3H GSM001/3
GSM001/3	3L	SF6 FREE	ED-Romania	140319	50 and 60	630	24	50	125	16	1	41,6	24V -15% +20%	IK08	IP3X	M1 - E3	M0 - E2	AFL	16; 1	C3H	Electrical	Yes	MV Switchgear 3LSF6 FREE 24 kV 16 kA AFL IP3X C3H GSM001/3
GSM001/3	3L	SF6 FREE	ED-Spain	140826	50 and 60	630	24	50	125	16	1	41,6	24V -15% +20%	IK08	IP3X	M1 - E3	M0 - E2	AFL	16; 1	C3H	Electrical	No	MV Switchgear 3LSF6 FREE 24 kV 16 kA AFL IP3X C3H GSM001/3
GSM001/3	3L	SF6	ED-Brazil	141180	50 and 60	630	24	50	125	16	1	41,6	24V -15% +20%	IK08	IP3X	M1 - E3	M0 - E2	AFL	16; 1	C3H	Electrical	Yes	MV Switchgear 3LSF6 24 kV 16 kA AFL IP3X C3H GSM001/3
GSM001/3	3L	SF6 FREE	ED-Brazil	140826	50 and 60	630	24	50	125	16	1	41,6	24V -15% +20%	IK08	IP3X	M1 - E3	M0 - E2	AFL	16; 1	C3H	Electrical	Yes	MV Switchgear 3LSF6 FREE 24 kV 16 kA AFL IP3X C3H GSM001/3
GSM001/3	3L	SF6 FREE	ED-Argentina	0109-0504	50 and 60	630	24	50	125	16	1	41,6	24V -15% +20%	IK08	IP3X	M1 - E3	M0 - E2	AFL	16; 1	C3H	Electrical	Yes	MV Switchgear 3LSF6 FREE 24 kV 16 kA AFL IP3X C3H GSM001/3
GSM001/3	3L	SF6	ED-Argentina	0109-0496	50 and 60	630	24	50	125	16	1	41,6	24V -15% +20%	IK08	IP3X	M1 - E3	M0 - E2	AFL	16; 1	C3H	Electrical	Yes	MV Switchgear 3LSF6 24 kV 16 kA AFL IP3X C3H GSM001/3
GSM001/3	3L	SF6 FREE	ED-Colombia	140771	50 and 60	630	24	50	125	16	1	41,6	24V -15% +20%	IK08	IP3X	M1 - E3	M0 - E2	AFL	16; 1	C3H	Electrical	Yes	MV Switchgear 3LSF6 FREE 24 kV 16 kA AFL IP3X C3H GSM001/3
GSM001/3	3L	SF6 FREE	ED-Chile	141199	50 and 60	630	24	50	125	16	1	41,6	24V -15% +20%	IK08	IP3X	M1 - E3	M0 - E2	AFL	16; 1	C3H	Electrical	Yes	MV Switchgear 3LSF6 FREE 24 kV 16 kA AFL IP3X C3H GSM001/3
GSM001/4	4L+1T	SF6 FREE	ED-Argentina	0109-0503	50 and 60	630	24	50	125	16	1	41,6	24V -15% +20%	IK08	IP3X	M1 - E3	M0 - E2	AFL	16; 1	C3H	Electrical	Yes	MV Switchgear 4L+1T SF6 FREE 24 kV 16 kA AFL IP3X C3H GSM001/4
GSM001/4	4L+1T	SF6	ED-Italy	162119	50 and 60	630	24	50	125	16	1	41,6	24V -15% +20%	IK08	IP3X	M1 - E3	M0 - E2	AFL	16; 1	C3H	Electrical	Yes	MV Switchgear 4L+1T SF6 24 kV 16 kA AFL IP3X C3H GSM001/4
GSM001/4	4L+1T	SF6 FREE	ED-Italy	140320	50 and 60	630	24	50	125	16	1	41,6	24V -15% +20%	IK08	IP3X	M1 - E3	M0 - E2	AFL	16; 1	C3H	Electrical	Yes	MV Switchgear 4L+1T SF6 FREE 24 kV 16 kA AFL IP3X C3H GSM001/4
GSM001/4	4L+1T	SF6	ED-Colombia	140404	50 and 60	630	24	50	125	16	1	41,6	24V -15% +20%	IK08	IP3X	M1 - E3	M0 - E2	AFL	16; 1	C3H	Electrical	Yes	MV Switchgear 4L+1T SF6 24 kV 16 kA AFL IP3X C3H GSM001/4
GSM001/4	4L+1T	SF6	ED-Romania	140045	50 and 60	630	24	50	125	16	1	41,6	24V -15% +20%	IK08	IP3X	M1 - E3	M0 - E2	AFL	16; 1	C3H	Electrical	Yes	MV Switchgear 4L+1T SF6 24 kV 16 kA AFL IP3X C3H GSM001/4
GSM001/4	4L+1T	SF6 FREE	ED-Romania	140320	50 and 60	630	24	50	125	16	1	41,6	24V -15% +20%	IK08	IP3X	M1 - E3	M0 - E2	AFL	16; 1	C3H	Electrical	Yes	MV Switchgear 4L+1T SF6 FREE 24 kV 16 kA AFL IP3X C3H GSM001/4
GSM001/4	4L+1T	SF6	ED-Brazil	141178	50 and 60	630	24	50	125	16	1	41,6	24V -15% +20%	IK08	IP3X	M1 - E3	M0 - E2	AFL	16; 1	C3H	Electrical	Yes	MV Switchgear 4L+1T SF6 24 kV 16 kA AFL IP3X C3H GSM001/4
GSM001/4	4L+1T	SF6 FREE	ED-Brazil	140824	50 and 60	630	24	50	125	16	1	41,6	24V -15% +20%	IK08	IP3X	M1 - E3	M0 - E2	AFL	16; 1	C3H	Electrical	Yes	MV Switchgear 4L+1T SF6 FREE 24 kV 16 kA AFL IP3X C3H GSM001/4
GSM001/4	4L+1T	SF6	ED-Argentina	0109-0495	50 and 60	630	24	50	125	16	1	41,6	24V -15% +20%	IK08	IP3X	M1 - E3	M0 - E2	AFL	16; 1	C3H	Electrical	Yes	MV Switchgear 4L+1T SF6 24 kV 16 kA AFL IP3X C3H GSM001/4
GSM001/4	4L+1T	SF6 FREE	ED-Colombia	140772	50 and 60	630	24	50	125	16	1	41,6	24V -15% +20%	IK08	IP3X	M1 - E3	M0 - E2	AFL	16; 1	C3H	Electrical	Yes	MV Switchgear 4L+1T SF6 FREE 24 kV 16 kA AFL IP3X C3H GSM001/4
GSM001/4	4L+1T	SF6 FREE	ED-Chile	141198	50 and 60	630	24	50	125	16	1	41,6	24V -15% +20%	IK08	IP3X	M1 - E3	M0 - E2	AFL	16; 1	C3H	Electrical	Yes	MV Switchgear 4L+1T SF6 FREE 24 kV 16 kA AFL IP3X C3H GSM001/4
GSM001/4	4L+1T	SF6	ED-Chile	141194	50 and 60	630	24	50	125	16	1	41,6	24V -15% +20%	IK08	IP3X	M1 - E3	M0 - E2	AFL	16; 1	C3H	Electrical	Yes	MV Switchgear 4L+1T SF6 24 kV 16 kA AFL IP3X C3H GSM001/4
GSM001/5	4L	SF6	ED-Italy	162120	50 and 60	630	24	50	125	16	1	41,6	24V -15% +20%	IK08	IP3X	M1 - E3	M0 - E2	AFL	16; 1	C3H	Electrical	Yes	MV Switchgear 4LSF6 24 kV 16 kA AFL IP3X C3H GSM001/5
GSM001/5	4L	SF6 FREE	ED-Italy	140321	50 and 60	630	24	50	125	16	1	41,6	24V -15% +20%	IK08	IP3X	M1 - E3	M0 - E2	AFL	16; 1	C3H	Electrical	Yes	MV Switchgear 4LSF6 FREE 24 kV 16 kA AFL IP3X C3H GSM001/5
GSM001/5	4L	SF6	ED-Romania	140046	50 and 60	630	24	50	125	16	1	41,6	24V -15% +20%	IK08	IP3X	M1 - E3	M0 - E2	AFL	16; 1	C3H	Electrical	Yes	MV Switchgear 4LSF6 24 kV 16 kA AFL IP3X C3H GSM001/5
GSM001/5	4L	SF6 FREE	ED-Romania	140321	50 and 60	630	24	50	125	16	1	41,6	24V -15% +20%	IK08	IP3X	M1 - E3	M0 - E2	AFL	16; 1	C3H	Electrical	Yes	MV Switchgear 4LSF6 FREE 24 kV 16 kA AFL IP3X C3H GSM001/5
GSM001/5	4L	SF6	ED-Brazil	141179	50 and 60	630	24	50	125	16	1	41,6	24V -15% +20%	IK08	IP3X	M1 - E3	M0 - E2	AFL	16; 1	C3H	Electrical	Yes	MV Switchgear 4LSF6 24 kV 16 kA AFL IP3X C3H GSM001/5
GSM001/5	4L	SF6 FREE	ED-Brazil	140825	50 and 60	630	24	50	125	16	1	41,6	24V -15% +20%	IK08	IP3X	M1 - E3	M0 - E2	AFL	16; 1	C3H	Electrical	Yes	MV Switchgear 4LSF6 FREE 24 kV 16 kA AFL IP3X C3H GSM001/5
GSM001/5	4L	SF6 FREE	ED-Argentina	0109-0505	50 and 60	630	24	50	125	16	1	41,6	24V -15% +20%	IK08	IP3X	M1 - E3	M0 - E2	AFL	16; 1	C3H	Electrical	Yes	MV Switchgear 4LSF6 FREE 24 kV 16 kA AFL IP3X C3H GSM001/5
GSM001/5	4L	SF6	ED-Argentina	0109-0498	50 and 60	630	24	50	125	16	1	41,6	24V -15% +20%	IK08	IP3X	M1 - E3	M0 - E2	AFL	16; 1	C3H	Electrical	Yes	MV Switchgear 4LSF6 24 kV 16 kA AFL IP3X C3H GSM001/5
GSM001/5	4L	SF6 FREE	ED-Chile	141197	50 and 60	630	24	50	125	16	1	41,6	24V -15% +20%	IK08	IP3X	M1 - E3	M0 - E2	AFL	16; 1	C3H	Electrical	Yes	MV Switchgear 4LSF6 FREE 24 kV 16 kA AFL IP3X C3H GSM001/5
GSM001/5	4L	SF6	ED-Chile	141193	50 and 60	630	24	50	125	16	1	41,6	24V -15% +20%	IK08	IP3X	M1 - E3	M0 - E2	AFL	16; 1	C3H	Electrical	Yes	MV Switchgear 4LSF6 24 kV 16 kA AFL IP3X C3H GSM001/5
GSM001/6	2L+1T	SF6	ED-Spain	140925	50 and 60	630	24	50	125	20	1	52	24V -15% +20%	IK08	IP51	M1 - E3	M0 - E2	AFL	20; 1	C5H	Electrical	No	MV Switchgear 2L+1T SF6 24 kV 20 kA AFL IP51 C5H GSM001/6
GSM001/7	2L+1T	SF6	ED-Brazil	141175	50 and 60	630	24	50	125	16	1	41,6	24V -15% +20%	IK08	IP51	M1 - E3	M0 - E2	AFL	16; 1	C5H	Electrical	Yes	MV Switchgear 2L+1T SF6 24 kV 16 kA AFL IP51 C5H GSM001/7
GSM001/7	2L+1T	SF6 FREE	ED-Brazil	140821	50 and 60	630	24	50	125	16	1	41,6	24V -15% +20%	IK08	IP51	M1 - E3	M0 - E2	AFL	16; 1	C5H	Electrical	Yes	MV Switchgear 2L+1T SF6 FREE 24 kV 16 kA AFL IP51 C5H GSM001/7

Technical Specification code: GRI-GRI-MAT-E&C-0002

Version no.3 dated 03/10/2022

Subject: Enel Grids - GSM001 - Medium Voltage Gas Insulated Switchgears for secondary distribution substations

Application Areas

Perimeter: Global

Staff Function: -

Service Function: -

Business Line: Enel Grids

Type code	Configuration	GIS technology	Distribution Company and Contry	Country Code	Rated frequency fr [Hz]	Rated normal current I _n [A]	Rated Voltage U _r [kV]	Rated power-frequency withstand voltage U _a [kV]	Rated lightning impulse withstand voltage U _p [kV]	Rated short-time withstand current I _k [kA]	Rated duration of short circuit t _k [s]	Rated peak withstand current I _p [kA]	Rated supply voltage of closing and opening devices and of auxiliary circuit V _{cc}	IK degree	IP degree	SD - Mechanical endurance class- Electrical endurance class	ES - Mechanical endurance class- Electrical endurance class	Classification IAC	Arc fault current and duration I _k (kA); t _A (s)	Protective Coating	Command Type	Busbar Socket	Description
GSM001/8	2L+2T	SF6 FREE	ED-Italy	140322	50 and 60	630	24	50	125	16	1	41,6	24V -15% +20%	IK08	IP3X	M1 – E3	M0 – E2	AFL	16; 1	C3H	Electrical	Yes	MV Switchgear 2L+2T SF6 FREE 24 kV 16 kA AFL IP3X C3H GSM001/8
GSM001/8	2L+2T	SF6	ED-Colombia	140405	50 and 60	630	24	50	125	16	1	41,6	24V -15% +20%	IK08	IP3X	M1 – E3	M0 – E2	AFL	16; 1	C3H	Electrical	Yes	MV Switchgear 2L+2T SF6 24 kV 16 kA AFL IP3X C3H GSM001/8
GSM001/8	2L+2T	SF6	ED-Romania	140047	50 and 60	630	24	50	125	16	1	41,6	24V -15% +20%	IK08	IP3X	M1 – E3	M0 – E2	AFL	16; 1	C3H	Electrical	Yes	MV Switchgear 2L+2T SF6 24 kV 16 kA AFL IP3X C3H GSM001/8
GSM001/8	2L+2T	SF6 FREE	ED-Romania	140322	50 and 60	630	24	50	125	16	1	41,6	24V -15% +20%	IK08	IP3X	M1 – E3	M0 – E2	AFL	16; 1	C3H	Electrical	Yes	MV Switchgear 2L+2T SF6 FREE 24 kV 16 kA AFL IP3X C3H GSM001/8
GSM001/8	2L+2T	SF6	ED-Spain	140225	50 and 60	630	24	50	125	16	1	41,6	24V -15% +20%	IK08	IP3X	M1 – E3	M0 – E2	AFL	16; 1	C3H	Electrical	No	MV Switchgear 2L+2T SF6 24 kV 16 kA AFL IP3X C3H GSM001/8
GSM001/8	2L+2T	SF6 FREE	ED-Spain	140805	50 and 60	630	24	50	125	16	1	41,6	24V -15% +20%	IK08	IP3X	M1 – E3	M0 – E2	AFL	16; 1	C3H	Electrical	No	MV Switchgear 2L+2T SF6 FREE 24 kV 16 kA AFL IP3X C3H GSM001/8
GSM001/8	2L+2T	SF6 FREE	ED-Argentina	0109-0502	50 and 60	630	24	50	125	16	1	41,6	24V -15% +20%	IK08	IP3X	M1 – E3	M0 – E2	AFL	16; 1	C3H	Electrical	Yes	MV Switchgear 2L+2T SF6 FREE 24 kV 16 kA AFL IP3X C3H GSM001/8
GSM001/8	2L+2T	SF6	ED-Argentina	0109-0494	50 and 60	630	24	50	125	16	1	41,6	24V -15% +20%	IK08	IP3X	M1 – E3	M0 – E2	AFL	16; 1	C3H	Electrical	Yes	MV Switchgear 2L+2T SF6 24 kV 16 kA AFL IP3X C3H GSM001/8
GSM001/8	2L+2T	SF6 FREE	ED-Colombia	140773	50 and 60	630	24	50	125	16	1	41,6	24V -15% +20%	IK08	IP3X	M1 – E3	M0 – E2	AFL	16; 1	C3H	Electrical	Yes	MV Switchgear 2L+2T SF6 FREE 24 kV 16 kA AFL IP3X C3H GSM001/8
GSM001/8	2L+2T	SF6	ED-Italy	140425	50 and 60	630	24	50	125	16	1	41,6	24V -15% +20%	IK08	IP3X	M1 – E3	M0 – E2	AFL	16; 1	C3H	Electrical	Yes	MV Switchgear 2L+2T SF6 24 kV 16 kA AFL IP3X C3H GSM001/8
GSM001/9	3L+1T	SF6	ED-Spain	140927	50 and 60	630	24	50	125	20	1	52	24V -15% +20%	IK08	IP51	M1 – E3	M0 – E2	AFL	20;1	C5H	Electrical	No	MV Switchgear 3L+1T SF6 24 kV 20 kA AFL IP51 C5H GSM001/9
GSM001/10	1L	SF6	ED-Spain	140294	50 and 60	630	24	50	125	16	1	41,6	24V -15% +20%	IK08	IP3X	M1 – E3	M0 – E2	AFL	16; 1	C3H	Electrical	No	MV Switchgear 1L SF6 24 kV 16 kA AFL IP3X C3H GSM001/10
GSM001/10	1L	SF6 FREE	ED-Spain	140825	50 and 60	630	24	50	125	16	1	41,6	24V -15% +20%	IK08	IP3X	M1 – E3	M0 – E2	AFL	16; 1	C3H	Electrical	No	MV Switchgear 1L SF6 FREE 24 kV 16 kA AFL IP3X C3H GSM001/10
GSM001/11	3L	SF6	ED-Brazil	141173	50 and 60	630	24	50	125	16	1	41,6	24V -15% +20%	IK08	IP51	M1 – E3	M0 – E2	AFL	16; 1	C5H	Electrical	Yes	MV Switchgear 3L SF6 24 kV 16 kA AFL IP51 C5H GSM001/11
GSM001/11	3L	SF6 FREE	ED-Brazil	140819	50 and 60	630	24	50	125	16	1	41,6	24V -15% +20%	IK08	IP51	M1 – E3	M0 – E2	AFL	16; 1	C5H	Electrical	Yes	MV Switchgear 3L SF6 FREE 24 kV 16 kA AFL IP51 C5H GSM001/11
GSM001/12	4L+1T	SF6	ED-Brazil	141171	50 and 60	630	24	50	125	16	1	41,6	24V -15% +20%	IK08	IP51	M1 – E3	M0 – E2	AFL	16; 1	C5H	Electrical	Yes	MV Switchgear 4L+1T SF6 24 kV 16 kA AFL IP51 C5H GSM001/12
GSM001/12	4L+1T	SF6 FREE	ED-Brazil	140817	50 and 60	630	24	50	125	16	1	41,6	24V -15% +20%	IK08	IP51	M1 – E3	M0 – E2	AFL	16; 1	C5H	Electrical	Yes	MV Switchgear 4L+1T SF6 FREE 24 kV 16 kA AFL IP51 C5H GSM001/12
GSM001/13	4L	SF6	ED-Brazil	141172	50 and 60	630	24	50	125	16	1	41,6	24V -15% +20%	IK08	IP51	M1 – E3	M0 – E2	AFL	16; 1	C5H	Electrical	Yes	MV Switchgear 4L SF6 24 kV 16 kA AFL IP51 C5H GSM001/13
GSM001/13	4L	SF6 FREE	ED-Brazil	140818	50 and 60	630	24	50	125	16	1	41,6	24V -15% +20%	IK08	IP51	M1 – E3	M0 – E2	AFL	16; 1	C5H	Electrical	Yes	MV Switchgear 4L SF6 FREE 24 kV 16 kA AFL IP51 C5H GSM001/13
GSM001/14	2L+1T	SF6	ED-Peru	140342	50 and 60	630	24	50	125	20	1	52	24V -15% +20%	IK08	IP3X	M1 – E3	M0 – E2	AFL	20; 1	C5H	Electrical	Yes	MV Switchgear 2L+1T SF6 24 kV 20 kA AFL IP3X C5H GSM001/14
GSM001/14	2L+1T	SF6 FREE	ED-Peru	140792	50 and 60	630	24	50	125	20	1	52	24V -15% +20%	IK08	IP3X	M1 – E3	M0 – E2	AFL	20; 1	C5H	Electrical	Yes	MV Switchgear 2L+1T SF6 FREE 24 kV 20 kA AFL IP3X C5H GSM001/14
GSM001/15	3L+1T	SF6	ED-Peru	140339	50 and 60	630	24	50	125	20	1	52	24V -15% +20%	IK08	IP3X	M1 – E3	M0 – E2	AFL	20; 1	C5H	Electrical	Yes	MV Switchgear 3L+1T SF6 24 kV 20 kA AFL IP3X C5H GSM001/15
GSM001/16	1T	SF6	ED-Spain	140298	50 and 60	630	24	50	125	16	1	41,6	24V -15% +20%	IK08	IP3X	M1 – E3	M0 – E2	AFL	16; 1	C3H	Electrical	No	MV Switchgear 1T SF6 24 kV 16 kA AFL IP3X C3H GSM001/16
GSM001/16	1T	SF6 FREE	ED-Spain	140803	50 and 60	630	24	50	125	16	1	41,6	24V -15% +20%	IK08	IP3X	M1 – E3	M0 – E2	AFL	16; 1	C3H	Electrical	No	MV Switchgear 1T SF6 FREE 24 kV 16 kA AFL IP3X C3H GSM001/16
GSM001/17	2L+1T	SF6 FREE	ED-Spain	140802	50 and 60	630	24	50	125	20	1	52	24V -15% +20%	IK08	IP3X	M1 – E3	M0 – E2	AFL	20;1	C3H	Electrical	No	MV Switchgear 2L+1T SF6 FREE 24 kV 20 kA AFL IP3X C3H GSM001/17
GSM001/17	2L+1T	SF6	ED-Spain	140483	50 and 60	630	24	50	125	20	1	52	24V -15% +20%	IK08	IP3X	M1 – E3	M0 – E2	AFL	20;1	C3H	Electrical	No	MV Switchgear 2L+1T SF6 24 kV 20 kA AFL IP3X C3H GSM001/17
GSM001/18	3L+1T	SF6 FREE	ED-Spain	140800	50 and 60	630	24	50	125	20	1	52	24V -15% +20%	IK08	IP3X	M1 – E3	M0 – E2	AFL	20;1	C3H	Electrical	No	MV Switchgear 3L+1T SF6 FREE 24 kV 20 kA AFL IP3X C3H GSM001/18
GSM001/18	3L+1T	SF6	ED-Spain	140281	50 and 60	630	24	50	125	20	1	52	24V -15% +20%	IK08	IP3X	M1 – E3	M0 – E2	AFL	20;1	C3H	Electrical	No	MV Switchgear 3L+1T SF6 24 kV 20 kA AFL IP3X C3H GSM001/18
GSM001/19	2L+2T	SF6 FREE	ED-Spain	140801	50 and 60	630	24	50	125	20	1	52	24V -15% +20%	IK08	IP3X	M1 – E3	M0 – E2	AFL	20;1	C3H	Electrical	No	MV Switchgear 2L+2T SF6 FREE 24 kV 20 kA AFL IP3X C3H GSM001/19
GSM001/19	2L+2T	SF6	ED-Spain	140280	50 and 60	630	24	50	125	20	1	52	24V -15% +20%	IK08	IP3X	M1 – E3	M0 – E2	AFL	20;1	C3H	Electrical	No	MV Switchgear 2L+2T SF6 24 kV 20 kA AFL IP3X C3H GSM001/19
GSM001/20	3L	SF6 FREE	ED-Spain	140804	50 and 60	630	24	50	125	20	1	52	24V -15% +20%	IK08	IP3X	M1 – E3	M0 – E2	AFL	20;1	C3H	Electrical	No	MV Switchgear 3L SF6 FREE 24 kV 20 kA AFL IP3X C3H GSM001/20
GSM001/20	3L	SF6	ED-Spain	140282	50 and 60	630	24	50	125	20	1	52	24V -15% +20%	IK08	IP3X	M1 – E3	M0 – E2	AFL	20;1	C3H	Electrical	No	MV Switchgear 3L SF6 24 kV 20 kA AFL IP3X C3H GSM001/20
GSM001/21	1L	SF6 FREE	ED-Spain	140824	50 and 60	630	24	50	125	20	1	52	24V -15% +20%	IK08	IP3X	M1 – E3	M0 – E2	AFL	20;1	C3H	Electrical	No	MV Switchgear 1L SF6 FREE 24 kV 20 kA AFL IP3X C3H GSM001/21
GSM001/21	1L	SF6	ED-Spain	140478	50 and 60	630	24	50	125	20	1	52	24V -15% +20%	IK08	IP3X	M1 – E3	M0 – E2	AFL	20;1	C3H	Electrical	No	MV Switchgear 1L SF6 24 kV 20 kA AFL IP3X C3H GSM001/21
GSM001/22	2L+2T	SF6	ED-Spain	140928	50 and 60	630	24	50	125	20	1	52	24V -15% +20%	IK08	IP51	M1 – E3	M0 – E2	AFL	20;1	C5H	Electrical	No	MV Switchgear 2L+2T SF6 24 kV 20 kA AFL IP51 C5H GSM001/22
GSM001/23	2L+1T	SF6	ED-Brazil	140835	50 and 60	630	36	70	170	16	1	41,6	24V -15% +20%	IK08	IP51	M1 – E3	M0 – E2	AFL	16; 1	C5H	Electrical	Yes	MV Switchgear 2L+1T SF6 36 kV 16 kA AFL IP51 C5H GSM001/23
GSM001/23	2L+1T	SF6 FREE	ED-Brazil	140811	50 and 60	630	36	70	170	16	1	41,6	24V -15% +20%	IK08	IP51	M1 – E3	M0 – E2	AFL	16; 1	C5H	Electrical	Yes	MV Switchgear 2L+1T SF6 FREE 36 kV 16 kA AFL IP51 C5H GSM001/23
GSM001/24	3L+1T	SF6	ED-Brazil	140834	50 and 60	630	36	70	170	16	1	41,6	24V -15% +20%	IK08	IP51	M1 – E3	M0 – E2	AFL	16; 1	C5H	Electrical	Yes	MV Switchgear 3L+1T SF6 36 kV 16 kA AFL IP51 C5H GSM001/24
GSM001/24	3L+1T	SF6 FREE	ED-Brazil	140810	50 and 60	630	36	70	170	16	1	41,6	24V -15% +20%	IK08	IP51	M1 – E3	M0 – E2	AFL	16; 1	C5H	Electrical	Yes	MV Switchgear 3L+1T SF6 FREE 36 kV 16 kA AFL IP51 C5H GSM001/24

Technical Specification code: GRI-GRI-MAT-E&C-0002

Version no.3 dated 03/10/2022

Subject: Enel Grids - GSM001 - Medium Voltage Gas Insulated Switchgears for secondary distribution substations

Application Areas

Perimeter: Global

Staff Function: -

Service Function: -

Business Line: Enel Grids

Type code	Configuration	GIS technology	Distribution Company and Contry	Country Code	Rated frequency fr [Hz]	Rated normal current I _n [A]	Rated Voltage U _r [kV]	Rated power-frequency withstand voltage U _a [kV]	Rated lightning impulse withstand voltage U _p [kV]	Rated short-time withstand current I _k [kA]	Rated duration of short circuit t _k [s]	Rated peak withstand current I _p [kA]	Rated supply voltage of closing and opening devices and of auxiliary circuit V _{cc}	IK degree	IP degree	SD - Mechanical endurance class- Electrical endurance class	ES - Mechanical endurance class- Electrical endurance class	Classification IAC	Arc fault current and duration I _k (kA); t _A (s)	Protective Coating	Command Type	Busbar Socket	Description
GSM001/25	3L	SF6	ED-Spain	140935	50 and 60	630	24	50	125	20	1	52	24V -15% +20%	IK08	IP51	M1 – E3	M0 – E2	AFL	20;1	C5H	Electrical	No	MV Switchgear 3L SF6 24 kV 20 kA AFL IP51 C5H GSM001/25
GSM001/26	1T	SF6 FREE	ED-Spain	140799	50 and 60	630	24	50	125	20	1	52	24V -15% +20%	IK08	IP3X	M1 – E3	M0 – E2	AFL	20;1	C3H	Electrical	No	MV Switchgear 1T SF6 FREE 24 kV 20 kA AFL IP3X C3H GSM001/26
GSM001/26	1T	SF6	ED-Spain	140255	50 and 60	630	24	50	125	20	1	52	24V -15% +20%	IK08	IP3X	M1 – E3	M0 – E2	AFL	20;1	C3H	Electrical	No	MV Switchgear 1T SF6 24 kV 20 kA AFL IP3X C3H GSM001/26
GSM001/27	2L+1T	SF6 FREE	ED-Spain	140798	50 and 60	630	36	70	170	16	1	41,6	24V -15% +20%	IK08	IP3X	M1 – E3	M0 – E2	AFL	16; 1	C3H	Electrical	No	MV Switchgear 2L+1T SF6 FREE 36 kV 16 kA AFL IP3X C3H GSM001/27
GSM001/27	2L+1T	SF6 FREE	ED-Italy	140323	50 and 60	630	36	70	170	16	1	41,6	24V -15% +20%	IK08	IP3X	M1 – E3	M0 – E2	AFL	16; 1	C3H	Electrical	Yes	MV Switchgear 2L+1T SF6 FREE 36 kV 16 kA AFL IP3X C3H GSM001/27
GSM001/27	2L+1T	SF6	ED-Spain	140285	50 and 60	630	36	70	170	16	1	41,6	24V -15% +20%	IK08	IP3X	M1 – E3	M0 – E2	AFL	16; 1	C3H	Electrical	No	MV Switchgear 2L+1T SF6 36 kV 16 kA AFL IP3X C3H GSM001/27
GSM001/27	2L+1T	SF6	ED-Brazil	141157	50 and 60	630	36	70	170	16	1	41,6	24V -15% +20%	IK08	IP3X	M1 – E3	M0 – E2	AFL	16; 1	C3H	Electrical	Yes	MV Switchgear 2L+1T SF6 36 kV 16 kA AFL IP3X C3H GSM001/27
GSM001/27	2L+1T	SF6 FREE	ED-Brazil	140814	50 and 60	630	36	70	170	16	1	41,6	24V -15% +20%	IK08	IP3X	M1 – E3	M0 – E2	AFL	16; 1	C3H	Electrical	Yes	MV Switchgear 2L+1T SF6 FREE 36 kV 16 kA AFL IP3X C3H GSM001/27
GSM001/27	2L+1T	SF6	ED-Italy	140195	50 and 60	630	36	70	170	16	1	41,6	24V -15% +20%	IK08	IP3X	M1 – E3	M0 – E2	AFL	16; 1	C3H	Electrical	Yes	MV Switchgear 2L+1T SF6 36 kV 16 kA AFL IP3X C3H GSM001/27
GSM001/28	3L+1T	SF6	ED-Italy	140419	50 and 60	630	36	70	170	16	1	41,6	24V -15% +20%	IK08	IP3X	M1 – E3	M0 – E2	AFL	16; 1	C3H	Electrical	Yes	MV Switchgear 3L+1T SF6 36 kV 16 kA AFL IP3X C3H GSM001/28
GSM001/28	3L+1T	SF6 FREE	ED-Spain	140797	50 and 60	630	36	70	170	16	1	41,6	24V -15% +20%	IK08	IP3X	M1 – E3	M0 – E2	AFL	16; 1	C3H	Electrical	No	MV Switchgear 3L+1T SF6 FREE 36 kV 16 kA AFL IP3X C3H GSM001/28
GSM001/28	3L+1T	SF6 FREE	ED-Italy	140324	50 and 60	630	36	70	170	16	1	41,6	24V -15% +20%	IK08	IP3X	M1 – E3	M0 – E2	AFL	20; 1	C3H	Electrical	Yes	MV Switchgear 3L+1T SF6 FREE 36 kV 16 kA AFL IP3X C3H GSM001/28
GSM001/28	3L+1T	SF6	ED-Spain	140287	50 and 60	630	36	70	170	16	1	41,6	24V -15% +20%	IK08	IP3X	M1 – E3	M0 – E2	AFL	16; 1	C3H	Electrical	No	MV Switchgear 3L+1T SF6 36 kV 16 kA AFL IP3X C3H GSM001/28
GSM001/28	3L+1T	SF6	ED-Brazil	140989	50 and 60	630	36	70	170	16	1	41,6	24V -15% +20%	IK08	IP3X	M1 – E3	M0 – E2	AFL	16; 1	C3H	Electrical	Yes	MV Switchgear 3L+1T SF6 36 kV 16 kA AFL IP3X C3H GSM001/28
GSM001/28	3L+1T	SF6 FREE	ED-Brazil	140813	50 and 60	630	36	70	170	16	1	41,6	24V -15% +20%	IK08	IP3X	M1 – E3	M0 – E2	AFL	16; 1	C3H	Electrical	Yes	MV Switchgear 3L+1T SF6 FREE 36 kV 16 kA AFL IP3X C3H GSM001/28
GSM001/29	2L+2T	SF6 FREE	ED-Spain	140796	50 and 60	630	36	70	170	16	1	41,6	24V -15% +20%	IK08	IP3X	M1 – E3	M0 – E2	AFL	16; 1	C3H	Electrical	No	MV Switchgear 2L+2T SF6 FREE 36 kV 16 kA AFL IP3X C3H GSM001/29
GSM001/29	2L+2T	SF6	ED-Spain	140286	50 and 60	630	36	70	170	16	1	41,6	24V -15% +20%	IK08	IP3X	M1 – E3	M0 – E2	AFL	16; 1	C3H	Electrical	No	MV Switchgear 2L+2T SF6 36 kV 16 kA AFL IP3X C3H GSM001/29
GSM001/30	1L	SF6 FREE	ED-Spain	140793	50 and 60	630	36	70	170	16	1	41,6	24V -15% +20%	IK08	IP3X	M1 – E3	M0 – E2	AFL	16; 1	C3H	Electrical	No	MV Switchgear 1L SF6 FREE 36 kV 16 kA AFL IP3X C3H GSM001/30
GSM001/30	1L	SF6	ED-Spain	140296	50 and 60	630	36	70	170	16	1	41,6	24V -15% +20%	IK08	IP3X	M1 – E3	M0 – E2	AFL	16; 1	C3H	Electrical	No	MV Switchgear 1L SF6 36 kV 16 kA AFL IP3X C3H GSM001/30
GSM001/31	1L	SF6	ED-Spain	140920	50 and 60	630	24	50	125	20	1	52	24V -15% +20%	IK08	IP51	M1 – E3	M0 – E2	AFL	20;1	C5H	Electrical	No	MV Switchgear 1L SF6 24 kV 20 kA AFL IP51 C5H GSM001/31
GSM001/32	3L	SF6	ED-Brazil	140833	50 and 60	630	36	70	170	16	1	41,6	24V -15% +20%	IK08	IP51	M1 – E3	M0 – E2	AFL	16; 1	C5H	Electrical	Yes	MV Switchgear 3L SF6 36 kV 16 kA AFL IP51 C5H GSM001/32
GSM001/32	3L	SF6 FREE	ED-Brazil	140809	50 and 60	630	36	70	170	16	1	41,6	24V -15% +20%	IK08	IP51	M1 – E3	M0 – E2	AFL	16; 1	C5H	Electrical	Yes	MV Switchgear 3L SF6 FREE 36 kV 16 kA AFL IP51 C5H GSM001/32
GSM001/33	3L+1T	SF6	ED-Brazil	141174	50 and 60	630	24	50	125	16	1	41,6	24V -15% +20%	IK08	IP51	M1 – E3	M0 – E2	AFL	16; 1	C5H	Electrical	Yes	MV Switchgear 3L+1T SF6 24 kV 16 kA AFL IP51 C5H GSM001/33
GSM001/33	3L+1T	SF6 FREE	ED-Brazil	140820	50 and 60	630	24	50	125	16	1	41,6	24V -15% +20%	IK08	IP51	M1 – E3	M0 – E2	AFL	16; 1	C5H	Electrical	Yes	MV Switchgear 3L+1T SF6 FREE 24 kV 16 kA AFL IP51 C5H GSM001/33
GSM001/34	3L+2T	SF6	ED-Brazil	140837	50 and 60	630	36	70	170	16	1	41,6	24V -15% +20%	IK08	IP3X	M1 – E3	M0 – E2	AFL	16; 1	C3H	Electrical	Yes	MV Switchgear 3L+2T SF6 36 kV 16 kA AFL IP3X C3H GSM001/34
GSM001/34	3L+2T	SF6 FREE	ED-Brazil	140802	50 and 60	630	36	70	170	16	1	41,6	24V -15% +20%	IK08	IP3X	M1 – E3	M0 – E2	AFL	16; 1	C3H	Electrical	Yes	MV Switchgear 3L+2T SF6 FREE 36 kV 16 kA AFL IP3X C3H GSM001/34
GSM001/35	1T	SF6 FREE	ED-Spain	140795	50 and 60	630	36	70	170	16	1	41,6	24V -15% +20%	IK08	IP3X	M1 – E3	M0 – E2	AFL	16; 1	C3H	Electrical	No	MV Switchgear 1T SF6 FREE 36 kV 16 kA AFL IP3X C3H GSM001/35
GSM001/35	1T	SF6	ED-Spain	140299	50 and 60	630	36	70	170	16	1	41,6	24V -15% +20%	IK08	IP3X	M1 – E3	M0 – E2	AFL	16; 1	C3H	Electrical	No	MV Switchgear 1T SF6 36 kV 16 kA AFL IP3X C3H GSM001/35
GSM001/36	2L+1T	SF6 FREE	ED-Spain	140794	50 and 60	630	36	70	170	20	1	52	24V -15% +20%	IK08	IP3X	M1 – E3	M0 – E2	AFL	20; 1	C3H	Electrical	No	MV Switchgear 2L+1T SF6 FREE 36 kV 20 kA AFL IP3X C3H GSM001/36
GSM001/36	2L+1T	SF6	ED-Spain	140481	50 and 60	630	36	70	170	20	1	52	24V -15% +20%	IK08	IP3X	M1 – E3	M0 – E2	AFL	20; 1	C3H	Electrical	No	MV Switchgear 2L+1T SF6 36 kV 20 kA AFL IP3X C3H GSM001/36
GSM001/37	3L+1T	SF6 FREE	ED-Spain	140792	50 and 60	630	36	70	170	20	1	52	24V -15% +20%	IK08	IP3X	M1 – E3	M0 – E2	AFL	20; 1	C3H	Electrical	No	MV Switchgear 3L+1T SF6 FREE 36 kV 20 kA AFL IP3X C3H GSM001/37
GSM001/37	3L+1T	SF6	ED-Spain	140292	50 and 60	630	36	70	170	20	1	52	24V -15% +20%	IK08	IP3X	M1 – E3	M0 – E2	AFL	20; 1	C3H	Electrical	No	MV Switchgear 3L+1T SF6 36 kV 20 kA AFL IP3X C3H GSM001/37
GSM001/38	2L+2T	SF6 FREE	ED-Spain	140791	50 and 60	630	36	70	170	20	1	52	24V -15% +20%	IK08	IP3X	M1 – E3	M0 – E2	AFL	20; 1	C3H	Electrical	No	MV Switchgear 2L+2T SF6 FREE 36 kV 20 kA AFL IP3X C3H GSM001/38
GSM001/38	2L+2T	SF6	ED-Spain	140291	50 and 60	630	36	70	170	20	1	52	24V -15% +20%	IK08	IP3X	M1 – E3	M0 – E2	AFL	20; 1	C3H	Electrical	No	MV Switchgear 2L+2T SF6 36 kV 20 kA AFL IP3X C3H GSM001/38
GSM001/39	3L	SF6 FREE	ED-Spain	140790	50 and 60	630	36	70	170	20	1	52	24V -15% +20%	IK08	IP3X	M1 – E3	M0 – E2	AFL	20; 1	C3H	Electrical	No	MV Switchgear 3L SF6 FREE 36 kV 20 kA AFL IP3X C3H GSM001/39
GSM001/39	3L	SF6	ED-Spain	140293	50 and 60	630	36	70	170	20	1	52	24V -15% +20%	IK08	IP3X	M1 – E3	M0 – E2	AFL	20; 1	C3H	Electrical	No	MV Switchgear 3L SF6 36 kV 20 kA AFL IP3X C3H GSM001/39
GSM001/40	1L	SF6 FREE	ED-Spain	140789	50 and 60	630	36	70	170	20	1	52	24V -15% +20%	IK08	IP3X	M1 – E3	M0 – E2	AFL	20; 1	C3H	Electrical	No	MV Switchgear 1L SF6 FREE 36 kV 20 kA AFL IP3X C3H GSM001/40
GSM001/40	1L	SF6	ED-Spain	140477	50 and 60	630	36	70	170	20	1	52	24V -15% +20%	IK08	IP3X	M1 – E3	M0 – E2	AFL	20; 1	C3H	Electrical	No	MV Switchgear 1L SF6 36 kV 20 kA AFL IP3X C3H GSM001/40

Technical Specification code: GRI-GRI-MAT-E&C-0002

Version no.3 dated 03/10/2022

Subject: Enel Grids - GSM001 - Medium Voltage Gas Insulated Switchgears for secondary distribution substations

Application Areas

Perimeter: Global

Staff Function: -

Service Function: -

Business Line: Enel Grids

Type code	Configuration	GIS technology	Distribution Company and Contry	Country Code	Rated frequency fr [Hz]	Rated normal current I _n [A]	Rated Voltage U _r [kV]	Rated power-frequency withstand voltage U _d [kV]	Rated lightning impulse withstand voltage U _p [kV]	Rated short-time withstand current I _k [kA]	Rated duration of short circuit t _k [s]	Rated peak withstand current I _p [kA]	Rated supply voltage of closing and opening devices and of auxiliary circuit V _{cc}	IK degree	IP degree	SD - Mechanical endurance class- Electrical endurance class	ES - Mechanical endurance class- Electrical endurance class	Classification IAC	Arc fault current and duration I _k (kA); t _a (s)	Protective Coating	Command Type	Busbar Socket	Description
GSM001/41	3L+2T	SF6	ED-Brazil	140830	50 and 60	630	36	70	170	16	1	41,6	24V -15% +20%	IK08	IP51	M1 - E3	M0 - E2	AFL	16; 1	C5H	Electrical	Yes	MV Switchgear 3L+2T SF6 36 kV 16 kA AFL IP51 C5H GSM001/41
GSM001/41	3L+2T	SF6 FREE	ED-Brazil	140806	50 and 60	630	36	70	170	16	1	41,6	24V -15% +20%	IK08	IP51	M1 - E3	M0 - E2	AFL	16; 1	C5H	Electrical	Yes	MV Switchgear 3L+2T SF6 FREE 36 kV 16 kA AFL IP51 C5H GSM001/41
GSM001/42	3L+2T	SF6	ED-Brazil	141177	50 and 60	630	24	50	125	16	1	41,6	24V -15% +20%	IK08	IP3X	M1 - E3	M0 - E2	AFL	16; 1	C3H	Electrical	Yes	MV Switchgear 3L+2T SF6 24 kV 16 kA AFL IP3X C3H GSM001/42
GSM001/42	3L+2T	SF6 FREE	ED-Brazil	140823	50 and 60	630	24	50	125	16	1	41,6	24V -15% +20%	IK08	IP3X	M1 - E3	M0 - E2	AFL	16; 1	C3H	Electrical	Yes	MV Switchgear 3L+2T SF6 FREE 24 kV 16 kA AFL IP3X C3H GSM001/42
GSM001/42	3L+2T	SF6 FREE	ED-Argentina	0109-0501	50 and 60	630	24	50	125	16	1	41,6	24V -15% +20%	IK08	IP3X	M1 - E3	M0 - E2	AFL	16; 1	C3H	Electrical	Yes	MV Switchgear 3L+2T SF6 FREE 24 kV 16 kA AFL IP3X C3H GSM001/42
GSM001/42	3L+2T	SF6	ED-Argentina	0109-0497	50 and 60	630	24	50	125	16	1	41,6	24V -15% +20%	IK08	IP3X	M1 - E3	M0 - E2	AFL	16; 1	C3H	Electrical	Yes	MV Switchgear 3L+2T SF6 24 kV 16 kA AFL IP3X C3H GSM001/42
GSM001/43	3L+2T	SF6	ED-Brazil	141159	50 and 60	630	24	50	125	16	1	41,6	24V -15% +20%	IK08	IP51	M1 - E3	M0 - E2	AFL	16; 1	C5H	Electrical	Yes	MV Switchgear 3L+2T SF6 24 kV 16 kA AFL IP51 C5H GSM001/43
GSM001/43	3L+2T	SF6 FREE	ED-Brazil	140816	50 and 60	630	24	50	125	16	1	41,6	24V -15% +20%	IK08	IP51	M1 - E3	M0 - E2	AFL	16; 1	C5H	Electrical	Yes	MV Switchgear 3L+2T SF6 FREE 24 kV 16 kA AFL IP51 C5H GSM001/43
GSM001/44	4L	SF6	ED-Brazil	140838	50 and 60	630	36	70	170	16	1	41,6	24V -15% +20%	IK08	IP3X	M1 - E3	M0 - E2	AFL	16; 1	C3H	Electrical	Yes	MV Switchgear 4L SF6 36 kV 16 kA AFL IP3X C3H GSM001/44
GSM001/44	4L	SF6 FREE	ED-Brazil	140804	50 and 60	630	36	70	170	16	1	41,6	24V -15% +20%	IK08	IP3X	M1 - E3	M0 - E2	AFL	16; 1	C3H	Electrical	Yes	MV Switchgear 4L SF6 FREE 36 kV 16 kA AFL IP3X C3H GSM001/44
GSM001/45	1T	SF6 FREE	ED-Spain	140788	50 and 60	630	36	70	170	20	1	52	24V -15% +20%	IK08	IP3X	M1 - E3	M0 - E2	AFL	20; 1	C3H	Electrical	No	MV Switchgear 1T SF6 FREE 36 kV 20 kA AFL IP3X C3H GSM001/45
GSM001/45	1T	SF6	ED-Spain	140263	50 and 60	630	36	70	170	20	1	52	24V -15% +20%	IK08	IP3X	M1 - E3	M0 - E2	AFL	20; 1	C3H	Electrical	No	MV Switchgear 1T SF6 36 kV 20 kA AFL IP3X C3H GSM001/45
GSM001/46	1L+1T	SF6	ED-Italy	140001	50 and 60	630	24	50	125	16	1	41,6	24V -15% +20%	IK08	IP3X	M1 - E3	M0 - E2	AFL	16; 1	C3H	Electrical	Yes	MV Switchgear 1L+1T SF6 24 kV 16 kA AFL IP3X C3H GSM001/46
GSM001/46	1L+1T	SF6 FREE	ED-Italy	140317	50 and 60	630	24	50	125	16	1	41,6	24V -15% +20%	IK08	IP3X	M1 - E3	M0 - E2	AFL	16; 1	C3H	Electrical	Yes	MV Switchgear 1L+1T SF6 FREE 24 kV 16 kA AFL IP3X C3H GSM001/46
GSM001/46	1L+1T	SF6 FREE	ED-Romania	140317	50 and 60	630	24	50	125	16	1	41,6	24V -15% +20%	IK08	IP3X	M1 - E3	M0 - E2	AFL	16; 1	C3H	Electrical	Yes	MV Switchgear 1L+1T SF6 FREE 24 kV 16 kA AFL IP3X C3H GSM001/46
GSM001/46	1L+1T	SF6 FREE	ED-Chile	141196	50 and 60	630	24	50	125	16	1	41,6	24V -15% +20%	IK08	IP3X	M1 - E3	M0 - E2	AFL	16; 1	C3H	Electrical	Yes	MV Switchgear 1L+1T SF6 FREE 24 kV 16 kA AFL IP3X C3H GSM001/46
GSM001/46	1L+1T	SF6	ED-Chile	141192	50 and 60	630	24	50	125	16	1	41,6	24V -15% +20%	IK08	IP3X	M1 - E3	M0 - E2	AFL	16; 1	C3H	Electrical	Yes	MV Switchgear 1L+1T SF6 24 kV 16 kA AFL IP3X C3H GSM001/46
GSM001/47	1T	SF6	ED-Spain	140934	50 and 60	630	24	50	125	20	1	52	24V -15% +20%	IK08	IP51	M1 - E3	M0 - E2	AFL	20; 1	C5H	Manual	No	MV Switchgear 1T SF6 24 kV 20 kA AFL IP51 C5H GSM001/47
GSM001/48	3L+AUX 15/20KV	SF6	ED-Spain	140922	50 and 60	630	24	50	125	20	1	52	24V -15% +20%	IK08	IP51	M1 - E3	M0 - E2	AFL	20; 1	C5H	Electrical	No	MV Switchgear 3L+AUX 15/20KV SF6 24 kV 20 kA AFL IP51 C5H GSM001/48
GSM001/49	4L	SF6	ED-Brazil	140832	50 and 60	630	36	70	170	16	1	41,6	24V -15% +20%	IK08	IP51	M1 - E3	M0 - E2	AFL	16; 1	C5H	Electrical	Yes	MV Switchgear 4L SF6 36 kV 16 kA AFL IP51 C5H GSM001/49
GSM001/49	4L	SF6 FREE	ED-Brazil	140808	50 and 60	630	36	70	170	16	1	41,6	24V -15% +20%	IK08	IP51	M1 - E3	M0 - E2	AFL	16; 1	C5H	Electrical	Yes	MV Switchgear 4L SF6 FREE 36 kV 16 kA AFL IP51 C5H GSM001/49
GSM001/50	AUX 15/20KV	SF6	ED-Spain	140921	50 and 60	630	24	50	125	20	1	52	24V -15% +20%	IK08	IP51	M1 - E3	M0 - E2	AFL	20; 1	C5H	Electrical	No	MV Switchgear AUX 15/20KV SF6 24 kV 20 kA AFL IP51 C5H GSM001/50
GSM001/54	3L+AUX 10/15KV	SF6 FREE	ED-Spain	140814	50 and 60	630	24	50	125	16	1	41,6	24V -15% +20%	IK08	IP3X	M1 - E3	M0 - E2	AFL	16; 1	C3H	Electrical	No	MV Switchgear 3L+AUX 10/15KV SF6 FREE 24 kV 16 kA AFL IP3X C3H GSM001/54
GSM001/54	3L+AUX 10/15KV	SF6	ED-Spain	140746	50 and 60	630	24	50	125	16	1	41,6	24V -15% +20%	IK08	IP3X	M1 - E3	M0 - E2	AFL	16; 1	C3H	Electrical	No	MV Switchgear 3L+AUX 10/15KV SF6 24 kV 16 kA AFL IP3X C3H GSM001/54
GSM001/55	3L+AUX 15/20KV	SF6 FREE	ED-Spain	140822	50 and 60	630	24	50	125	16	1	41,6	24V -15% +20%	IK08	IP3X	M1 - E3	M0 - E2	AFL	16; 1	C3H	Electrical	No	MV Switchgear 3L+AUX 15/20KV SF6 FREE 24 kV 16 kA AFL IP3X C3H GSM001/55
GSM001/55	3L+AUX 15/20KV	SF6	ED-Spain	140747	50 and 60	630	24	50	125	16	1	41,6	24V -15% +20%	IK08	IP3X	M1 - E3	M0 - E2	AFL	16; 1	C3H	Electrical	No	MV Switchgear 3L+AUX 15/20KV SF6 24 kV 16 kA AFL IP3X C3H GSM001/55
GSM001/56	AUX 10/15KV	SF6 FREE	ED-Spain	140821	50 and 60	630	24	50	125	16	1	41,6	24V -15% +20%	IK08	IP3X	M1 - E3	M0 - E2	AFL	16; 1	C3H	Electrical	No	MV Switchgear AUX 10/15KV SF6 FREE 24 kV 16 kA AFL IP3X C3H GSM001/56
GSM001/56	AUX 10/15KV	SF6	ED-Spain	140750	50 and 60	630	24	50	125	16	1	41,6	24V -15% +20%	IK08	IP3X	M1 - E3	M0 - E2	AFL	16; 1	C3H	Electrical	No	MV Switchgear AUX 10/15KV SF6 24 kV 16 kA AFL IP3X C3H GSM001/56
GSM001/57	AUX 15/20KV	SF6 FREE	ED-Spain	140820	50 and 60	630	24	50	125	16	1	41,6	24V -15% +20%	IK08	IP3X	M1 - E3	M0 - E2	AFL	16; 1	C3H	Electrical	No	MV Switchgear AUX 15/20KV SF6 FREE 24 kV 16 kA AFL IP3X C3H GSM001/57
GSM001/57	AUX 15/20KV	SF6	ED-Spain	140744	50 and 60	630	24	50	125	16	1	41,6	24V -15% +20%	IK08	IP3X	M1 - E3	M0 - E2	AFL	16; 1	C3H	Electrical	No	MV Switchgear AUX 15/20KV SF6 24 kV 16 kA AFL IP3X C3H GSM001/57
GSM001/58	AUX 10/15KV	SF6 FREE	ED-Spain	140817	50 and 60	630	24	50	125	20	1	52	24V -15% +20%	IK08	IP3X	M1 - E3	M0 - E2	AFL	20; 1	C3H	Electrical	No	MV Switchgear AUX 10/15KV SF6 FREE 24 kV 20 kA AFL IP3X C3H GSM001/58
GSM001/58	AUX 10/15KV	SF6	ED-Spain	140724	50 and 60	630	24	50	125	20	1	52	24V -15% +20%	IK08	IP3X	M1 - E3	M0 - E2	AFL	20; 1	C3H	Electrical	No	MV Switchgear AUX 10/15KV SF6 24 kV 20 kA AFL IP3X C3H GSM001/58
GSM001/59	AUX 15/20KV	SF6 FREE	ED-Spain	140816	50 and 60	630	24	50	125	20	1	52	24V -15% +20%	IK08	IP3X	M1 - E3	M0 - E2	AFL	20; 1	C3H	Electrical	No	MV Switchgear AUX 15/20KV SF6 FREE 24 kV 20 kA AFL IP3X C3H GSM001/59
GSM001/59	AUX 15/20KV	SF6	ED-Spain	140722	50 and 60	630	24	50	125	20	1	52	24V -15% +20%	IK08	IP3X	M1 - E3	M0 - E2	AFL	20; 1	C3H	Electrical	No	MV Switchgear AUX 15/20KV SF6 24 kV 20 kA AFL IP3X C3H GSM001/59
GSM001/60	3L+AUX 25KV	SF6 FREE	ED-Spain	140815	50 and 60	630	36	70	170	16	1	41,6	24V -15% +20%	IK08	IP3X	M1 - E3	M0 - E2	AFL	16; 1	C3H	Electrical	No	MV Switchgear 3L+AUX 25KV SF6 FREE 36 kV 16 kA AFL IP3X C3H GSM001/60
GSM001/60	3L+AUX 25KV	SF6	ED-Spain	140749	50 and 60	630	36	70	170	16	1	41,6	24V -15% +20%	IK08	IP3X	M1 - E3	M0 - E2	AFL	16; 1	C3H	Electrical	No	MV Switchgear 3L+AUX 25KV SF6 36 kV 16 kA AFL IP3X C3H GSM001/60
GSM001/61	3L+AUX 11KV	SF6 FREE	ED-Spain	140813	50 and 60	630	36	70	170	16	1	41,6	24V -15% +20%	IK08	IP3X	M1 - E3	M0 - E2	AFL	16; 1	C3H	Electrical	No	MV Switchgear 3L+AUX 11KV SF6 FREE 36 kV 16 kA AFL IP3X C3H GSM001/61
GSM001/61	3L+AUX 11KV	SF6	ED-Spain	140745	50 and 60	630	36	70	170	16	1	41,6	24V -15% +20%	IK08	IP3X	M1 - E3	M0 - E2	AFL	16; 1	C3H	Electrical	No	MV Switchgear 3L+AUX 11KV SF6 36 kV 16 kA AFL IP3X C3H GSM001/61

Technical Specification code: GRI-GRI-MAT-E&C-0002

Version no.3 dated 03/10/2022

Subject: Enel Grids - GSM001 - Medium Voltage Gas Insulated Switchgears for secondary distribution substations

Application Areas

Perimeter: Global

Staff Function: -

Service Function: -

Business Line: Enel Grids

Type code	Configuration	GIS technology	Distribution Company and Contry	Country Code	Rated frequency fr [Hz]	Rated normal current I _n [A]	Rated Voltage U _r [kV]	Rated power-frequency withstand voltage U _d [kV]	Rated lightning impulse withstand voltage U _p [kV]	Rated short-time withstand current I _k [kA]	Rated duration of short circuit t _k [s]	Rated peak withstand current I _p [kA]	Rated supply voltage of closing and opening devices and of auxiliary circuit V _{cc}	IK degree	IP degree	SD - Mechanical endurance class- Electrical endurance class	ES - Mechanical endurance class- Electrical endurance class	Classification IAC	Arc fault current and duration I _k (kA); t _k (s)	Protective Coating	Command Type	Busbar Socket	Description
GSM001/62	AUX 25KV	SF6 FREE	ED-Spain	140812	50 and 60	630	36	70	170	16	1	41,6	24V -15% +20%	IK08	IP3X	M1 - E3	M0 - E2	AFL	16; 1	C3H	Electrical	No	MV Switchgear AUX 25KV SF6 FREE 36 kV 16 kA AFL IP3X C3H GSM001/62
GSM001/62	AUX 25KV	SF6	ED-Spain	140743	50 and 60	630	36	70	170	16	1	41,6	24V -15% +20%	IK08	IP3X	M1 - E3	M0 - E2	AFL	16; 1	C3H	Electrical	No	MV Switchgear AUX 25KV SF6 36 kV 16 kA AFL IP3X C3H GSM001/62
GSM001/63	AUX 11KV	SF6 FREE	ED-Spain	140811	50 and 60	630	36	70	170	16	1	41,6	24V -15% +20%	IK08	IP3X	M1 - E3	M0 - E2	AFL	16; 1	C3H	Electrical	No	MV Switchgear AUX 11KV SF6 FREE 36 kV 16 kA AFL IP3X C3H GSM001/63
GSM001/63	AUX 11KV	SF6	ED-Spain	140755	50 and 60	630	36	70	170	16	1	41,6	24V -15% +20%	IK08	IP3X	M1 - E3	M0 - E2	AFL	16; 1	C3H	Electrical	No	MV Switchgear AUX 11KV SF6 36 kV 16 kA AFL IP3X C3H GSM001/63
GSM001/64	AUX 25KV	SF6 FREE	ED-Spain	140808	50 and 60	630	36	70	170	20	1	52	24V -15% +20%	IK08	IP3X	M1 - E3	M0 - E2	AFL	20; 1	C3H	Electrical	No	MV Switchgear AUX 25KV SF6 FREE 36 kV 20 kA AFL IP3X C3H GSM001/64
GSM001/64	AUX 25KV	SF6	ED-Spain	140721	50 and 60	630	36	70	170	20	1	52	24V -15% +20%	IK08	IP3X	M1 - E3	M0 - E2	AFL	20; 1	C3H	Electrical	No	MV Switchgear AUX 25KV SF6 36 kV 20 kA AFL IP3X C3H GSM001/64
GSM001/65	AUX 11KV	SF6 FREE	ED-Spain	140807	50 and 60	630	36	70	170	20	1	52	24V -15% +20%	IK08	IP3X	M1 - E3	M0 - E2	AFL	20; 1	C3H	Electrical	No	MV Switchgear AUX 11KV SF6 FREE 36 kV 20 kA AFL IP3X C3H GSM001/65
GSM001/65	AUX 11KV	SF6	ED-Spain	140723	50 and 60	630	36	70	170	20	1	52	24V -15% +20%	IK08	IP3X	M1 - E3	M0 - E2	AFL	20; 1	C3H	Electrical	No	MV Switchgear AUX 11KV SF6 36 kV 20 kA AFL IP3X C3H GSM001/65
GSM001/66	3L	SF6 FREE	ED-Spain	140823	50 and 60	630	36	70	170	16	1	41,6	24V -15% +20%	IK08	IP3X	M1 - E3	M0 - E2	AFL	16; 1	C3H	Electrical	No	MV Switchgear 3L SF6 FREE 36 kV 16 kA AFL IP3X C3H GSM001/66
GSM001/66	3L	SF6	ED-Brazil	140840	50 and 60	630	36	70	170	16	1	41,6	24V -15% +20%	IK08	IP3X	M1 - E3	M0 - E2	AFL	16; 1	C3H	Electrical	Yes	MV Switchgear 3L SF6 36 kV 16 kA AFL IP3X C3H GSM001/66
GSM001/66	3L	SF6 FREE	ED-Brazil	140812	50 and 60	630	36	70	170	16	1	41,6	24V -15% +20%	IK08	IP3X	M1 - E3	M0 - E2	AFL	16; 1	C3H	Electrical	Yes	MV Switchgear 3L SF6 FREE 36 kV 16 kA AFL IP3X C3H GSM001/66
GSM001/67	3L+AUX 10/15KV	SF6 FREE	ED-Spain	140819	50 and 60	630	24	50	125	20	1	52	24V -15% +20%	IK08	IP3X	M1 - E3	M0 - E2	AFL	20;1	C3H	Electrical	No	MV Switchgear 3L+AUX 10/15KV SF6 FREE 24 kV 20 kA AFL IP3X C3H GSM001/67
GSM001/67	3L+AUX 10/15KV	SF6	ED-Spain	140717	50 and 60	630	24	50	125	20	1	52	24V -15% +20%	IK08	IP3X	M1 - E3	M0 - E2	AFL	20; 1	C3H	Electrical	No	MV Switchgear 3L+AUX 10/15KV SF6 24 kV 20 kA AFL IP3X C3H GSM001/67
GSM001/68	3L+AUX 15/20KV	SF6 FREE	ED-Spain	140818	50 and 60	630	24	50	125	20	1	52	24V -15% +20%	IK08	IP3X	M1 - E3	M0 - E2	AFL	20;1	C3H	Electrical	No	MV Switchgear 3L+AUX 15/20KV SF6 FREE 24 kV 20 kA AFL IP3X C3H GSM001/68
GSM001/68	3L+AUX 15/20KV	SF6	ED-Spain	140718	50 and 60	630	24	50	125	20	1	52	24V -15% +20%	IK08	IP3X	M1 - E3	M0 - E2	AFL	20; 1	C3H	Electrical	No	MV Switchgear 3L+AUX 15/20KV SF6 24 kV 20 kA AFL IP3X C3H GSM001/68
GSM001/69	3L+AUX 25KV	SF6 FREE	ED-Spain	140810	50 and 60	630	36	70	170	20	1	52	24V -15% +20%	IK08	IP3X	M1 - E3	M0 - E2	AFL	20; 1	C3H	Electrical	No	MV Switchgear 3L+AUX 25KV SF6 FREE 36 kV 20 kA AFL IP3X C3H GSM001/69
GSM001/69	3L+AUX 25KV	SF6	ED-Spain	140719	50 and 60	630	36	70	170	20	1	52	24V -15% +20%	IK08	IP3X	M1 - E3	M0 - E2	AFL	20; 1	C3H	Electrical	No	MV Switchgear 3L+AUX 25KV SF6 36 kV 20 kA AFL IP3X C3H GSM001/69
GSM001/70	3L+AUX 11KV	SF6 FREE	ED-Spain	140809	50 and 60	630	36	70	170	20	1	52	24V -15% +20%	IK08	IP3X	M1 - E3	M0 - E2	AFL	20; 1	C3H	Electrical	No	MV Switchgear 3L+AUX 11KV SF6 FREE 36 kV 20 kA AFL IP3X C3H GSM001/70
GSM001/70	3L+AUX 11KV	SF6	ED-Spain	140720	50 and 60	630	36	70	170	20	1	52	24V -15% +20%	IK08	IP3X	M1 - E3	M0 - E2	AFL	20; 1	C3H	Electrical	No	MV Switchgear 3L+AUX 11KV SF6 36 kV 20 kA AFL IP3X C3H GSM001/70
GSM001/71	4L+1T	SF6	ED-Brazil	140839	50 and 60	630	36	70	170	16	1	41,6	24V -15% +20%	IK08	IP3X	M1 - E3	M0 - E2	AFL	16; 1	C3H	Electrical	Yes	MV Switchgear 4L+1T SF6 36 kV 16 kA AFL IP3X C3H GSM001/71
GSM001/71	4L+1T	SF6 FREE	ED-Brazil	140801	50 and 60	630	36	70	170	16	1	41,6	24V -15% +20%	IK08	IP3X	M1 - E3	M0 - E2	AFL	16; 1	C3H	Electrical	Yes	MV Switchgear 4L+1T SF6 FREE 36 kV 16 kA AFL IP3X C3H GSM001/71
GSM001/72	4L+1T	SF6	ED-Brazil	140831	50 and 60	630	36	70	170	16	1	41,6	24V -15% +20%	IK08	IP51	M1 - E3	M0 - E2	AFL	16; 1	C5H	Electrical	Yes	MV Switchgear 4L+1T SF6 36 kV 16 kA AFL IP51 C5H GSM001/72
GSM001/72	4L+1T	SF6 FREE	ED-Brazil	140807	50 and 60	630	36	70	170	16	1	41,6	24V -15% +20%	IK08	IP51	M1 - E3	M0 - E2	AFL	16; 1	C5H	Electrical	Yes	MV Switchgear 4L+1T SF6 FREE 36 kV 16 kA AFL IP51 C5H GSM001/72
GSM001/73	5L+1T	SF6	ED-Brazil	141176	50 and 60	630	24	50	125	16	1	41,6	24V -15% +20%	IK08	IP3X	M1 - E3	M0 - E2	AFL	16; 1	C3H	Electrical	Yes	MV Switchgear 5L+1T SF6 24 kV 16 kA AFL IP3X C3H GSM001/73
GSM001/73	5L+1T	SF6 FREE	ED-Brazil	140822	50 and 60	630	24	50	125	16	1	41,6	24V -15% +20%	IK08	IP3X	M1 - E3	M0 - E2	AFL	16; 1	C3H	Electrical	Yes	MV Switchgear 5L+1T SF6 FREE 24 kV 16 kA AFL IP3X C3H GSM001/73
GSM001/74	5L+1T	SF6	ED-Brazil	141158	50 and 60	630	24	50	125	16	1	41,6	24V -15% +20%	IK08	IP51	M1 - E3	M0 - E2	AFL	16; 1	C5H	Electrical	Yes	MV Switchgear 5L+1T SF6 24 kV 16 kA AFL IP51 C5H GSM001/74
GSM001/74	5L+1T	SF6 FREE	ED-Brazil	140815	50 and 60	630	24	50	125	16	1	41,6	24V -15% +20%	IK08	IP51	M1 - E3	M0 - E2	AFL	16; 1	C5H	Electrical	Yes	MV Switchgear 5L+1T SF6 FREE 24 kV 16 kA AFL IP51 C5H GSM001/74
GSM001/75	5L+1T	SF6	ED-Brazil	140836	50 and 60	630	36	70	170	16	1	41,6	24V -15% +20%	IK08	IP3X	M1 - E3	M0 - E2	AFL	16; 1	C3H	Electrical	Yes	MV Switchgear 5L+1T SF6 36 kV 16 kA AFL IP3X C3H GSM001/75
GSM001/75	5L+1T	SF6 FREE	ED-Brazil	140803	50 and 60	630	36	70	170	16	1	41,6	24V -15% +20%	IK08	IP3X	M1 - E3	M0 - E2	AFL	16; 1	C3H	Electrical	Yes	MV Switchgear 5L+1T SF6 FREE 36 kV 16 kA AFL IP3X C3H GSM001/75
GSM001/76	5L+1T	SF6	ED-Brazil	140829	50 and 60	630	36	70	170	16	1	41,6	24V -15% +20%	IK08	IP51	M1 - E3	M0 - E2	AFL	16; 1	C5H	Electrical	Yes	MV Switchgear 5L+1T SF6 36 kV 16 kA AFL IP51 C5H GSM001/76
GSM001/76	5L+1T	SF6 FREE	ED-Brazil	140805	50 and 60	630	36	70	170	16	1	41,6	24V -15% +20%	IK08	IP51	M1 - E3	M0 - E2	AFL	16; 1	C5H	Electrical	Yes	MV Switchgear 5L+1T SF6 FREE 36 kV 16 kA AFL IP51 C5H GSM001/76

**Technical Specification code: GRI-GRI-MAT-E&C-0002**

Version no.3 dated 03/10/2022

Subject: Enel Grids - GSM001 - Medium Voltage Gas Insulated Switchgears for secondary distribution substations**Application Areas**

Perimeter: Global

Staff Function: -

Service Function: -

Business Line: Enel Grids

7.2 SERVICE CONDITIONS

Switchgears shall be compliant with normal service conditions for indoor installation, as defined in IEC 62271-1, considering as minimum value of ambient temperature -15°C.

Maximum reference altitude shall be 1.500 m. (For Colombia 2.700 m)

The Manufacturer shall consider de-ratings related to altitudes up to 3.000 m for specific installations, these de-rating shall be subjected to **enel** approval.

Seismic level of apparatuses shall be compliant with:

- seismic severity 1 - PGA 0,5 g.
- acceptance class 2 according to IEC TS 62271-210.

Switchgears shall be suitable for installation in three-phases MV effectively and non-effectively earthed neutral system (solidly earthed, isolated, impedance earthed, resonant earthed and arc-suppression-coil-earth neutral system).

Unless otherwise indicated, the carpentry shall have a protective coating compliant with ISO 12944 with the following minimum features:

- Durability: High (H).
- Atmospheric corrosivity category:C3.

**Technical Specification code: GRI-GRI-MAT-E&C-0002**

Version no.3 dated 03/10/2022

Subject: Enel Grids - GSM001 - Medium Voltage Gas Insulated Switchgears for secondary distribution substations**Application Areas**

Perimeter: Global

Staff Function: -

Service Function: -

Business Line: Enel Grids

7.3 TECHNICAL CHARACTERISTICS

7.3.1 Switchgear characteristics

The switchgear shall be compliant with IEC 62271-200.

The solution for the insulation of the switchgear shall be SF6 or alternative gases (e.g. Dry air, Gases containing fluoroketone or perfluoronitrile, etc.). For SF6 insulation gas the characteristics of the *Virgin* gas shall meet the requirements of IEC 60376 and the humidity content shall be less than 15 ppm in weight. In addition, no condensation shall occur during operation at the minimum temperatures described in §7.2.

For SF6 switchgear technology the gas-filled compartment volume shall be less than 1500 liters, its filling shall be performed such as the maximum relative pressure at 45 °C does not exceed 0,5 Bar. For SF6-free switchgear technology any solution is acceptable.

The expected operating life of the equipment, regarding leakage performance, shall be 40 years, the gas pressure shall remain greater than (or equal) the minimum operating value.

To fulfil the expected operating life requirement, the leakage rate considered to be 0,1 % per year according to IEC 62271-1.

The tank shall be exclusively filled with gas in the factory. The elements used for filling the gas in the factory, or to recover it at the end of life, shall be identified with a self-adhesive plate protected from accidental shocks. It shall contain the following information in the country language *Remove the cap only for recovery purposes at the end of life of the switchgear.*

Modular MV Switchgears shall be designed such as busbar extension is foreseen from both sides of the functional unit (left and right).

Compact MV Switchgears, also known as Ring Main Unit (RMU), could be manufactured with a single gas insulated tank containing the busbars, switching devices, and interconnections or from modular functional units assembled along the busbars by means of coupling device.

When the RMU is built-on using modular *units*, the manufacturer shall ensure that transport, handling, and installation is equivalent to a Compact solution. In addition, the coupling device shall not be accessible, i.e., IP3X between modular units shall be ensured.

**Technical Specification code: GRI-GRI-MAT-E&C-0002**

Version no.3 dated 03/10/2022

Subject: Enel Grids - GSM001 - Medium Voltage Gas Insulated Switchgears for secondary distribution substations**Application Areas**

Perimeter: Global

Staff Function: -

Service Function: -

Business Line: Enel Grids

Each gas-filled compartment shall have an overpressure valve, equipped with a metallic disc for protection against accidental stress and placed at a suitable distance from the valve.

MV Switchgears shall be built-on with external plug-in type bushings according to EN 50181, particularly:

- Line Functional Unit (L): Plug-in Type C bushings, 630 A rated current, equipped with Low Power Voltage Transformers (LPVT) according to GSCT005.
- Transformer Protection Functional Unit (T): Plug-in Type A bushings, 250 A rated current, for 24 kV switchgears and Type B for 36 kV Switchgears.

Equipment using SF6 FREE GAS shall have the front of the electrical control in green (RAL code to be defined in agreement with Enel).

Technical Specification code: GRI-GRI-MAT-E&C-0002

Version no.3 dated 03/10/2022

Subject: Enel Grids - GSM001 - Medium Voltage Gas Insulated Switchgears for secondary distribution substations
Application Areas

Perimeter: Global

Staff Function: -

Service Function: -

Business Line: Enel Grids

7.3.2 Rated characteristics

Rated Voltage (U_r)	[kV]	24	36
Rated short-duration power-frequency withstand voltage (U_d) –N Common value	[kV]	50	70
Rated short-duration power-frequency withstand voltage (U_d) – Across the isolating distance	[kV]	60	80
Rated lightning impulse withstand voltage (U_p) – Common value	[kV]	125	170
Rated lightning impulse withstand voltage (U_p) - Across the isolating distance	[kV]	145	195
Rated frequency (f_r) (*)	[Hz]	50 and 60	
Rated normal current (I_r)			
- for busbars and lines	[A]	630	
- for transformer derivation	[A]	200	
Rated short-time withstand current (I_k)	[kA]	16/20	
Rated peak withstand current (I_p)	[kA]	41,6/52	
Rated duration of short-circuit (t_k)	[s]	1	
Degree of protection for the whole enclosure except for the operating devices:			
- Argentina		IP3X**	
- Italy			
- Romania			
- Spain			
- Brazil			
- Chile			
- Colombia			
- Peru			
Degree of protection for the operating devices (even with the operating lever inserted)			
IP2XC			
Degree of protection of the external part of the switchgear			
IK08			
Internal arc test	Type of accessibility	AFL	
	Rated arc fault current (I_A)	[kA]	16/20
	Rated arc fault duration (t_A)	[s]	1
Rated supply voltage of closing and opening devices and of auxiliary circuit			
[Vcc] 24V -15% +20%			
Expected operating life regarding leakage performance			
40 years			

Table 2 - Characteristics of the switchgear

(*) The range of rated frequencies can vary according to the National Regulations and shall not affect the proper behavior of the equipment.

(**) For special applications IP51 could be requested.

Subject: Enel Grids - GSM001 - Medium Voltage Gas Insulated Switchgears for secondary distribution substations

Application Areas

Perimeter: Global

Staff Function: -

Service Function: -

Business Line: Enel Grids

7.3.3 Functional Unit Schemes

In the figures below the options for each functional unit are depicted.

L – LINE FUNCTIONAL UNIT

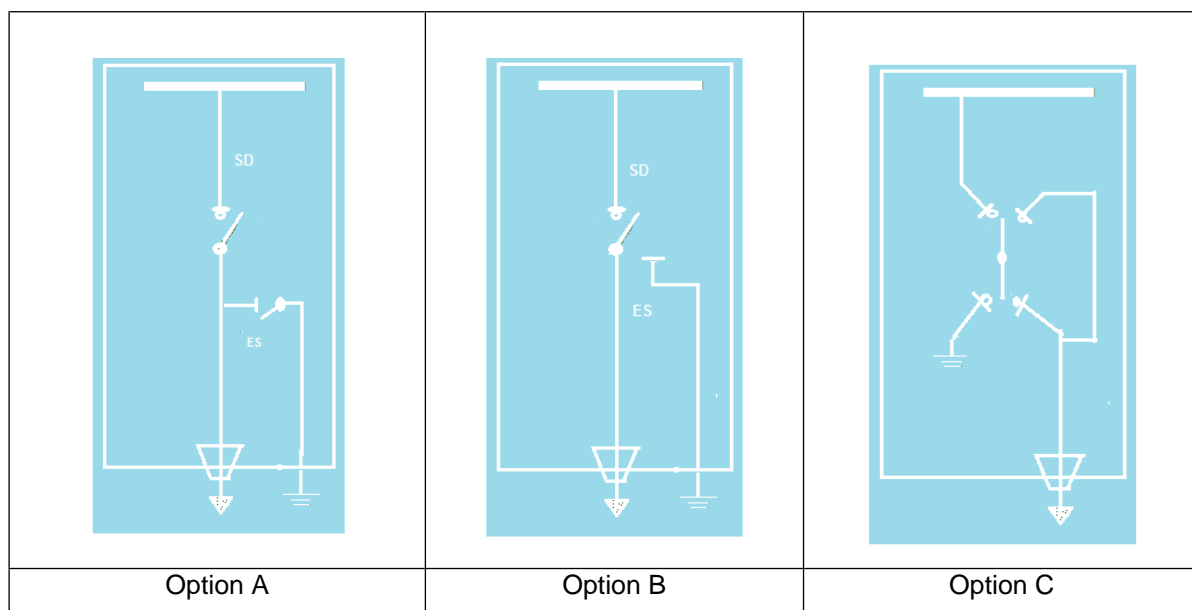

Figure 1 – Line Functional unit single line diagrams

OPTION A: Configuration with:

- 1 Switch-disconnector with 2 positions (OPEN – CLOSED)
- 1 Earthing switch with 2 positions (OPEN – EARTHED)

OPTION B/C: Configuration with:

- 1 Switch-disconnector / Earthing switch with 3 positions (EARTHED - OPEN – CLOSED)

Further single line diagrams could be proposed and implemented after Enel technical department approval.

Subject: Enel Grids - GSM001 - Medium Voltage Gas Insulated Switchgears for secondary distribution substations

Application Areas

Perimeter: Global

Staff Function: -

Service Function: -

Business Line: Enel Grids

T - TRANSFORMER PROTECTION FUNCTIONAL UNIT

Figure 2 – Transformer Protection Functional unit single line diagrams

OPTION A/B: Configuration with:

- 1 Switch-disconnector with 2 positions (OPEN – CLOSED)
- 2 Earthing switches (ES1/ES2) with 2 positions (OPEN – EARTHED)

OPTION B/C: Configuration with

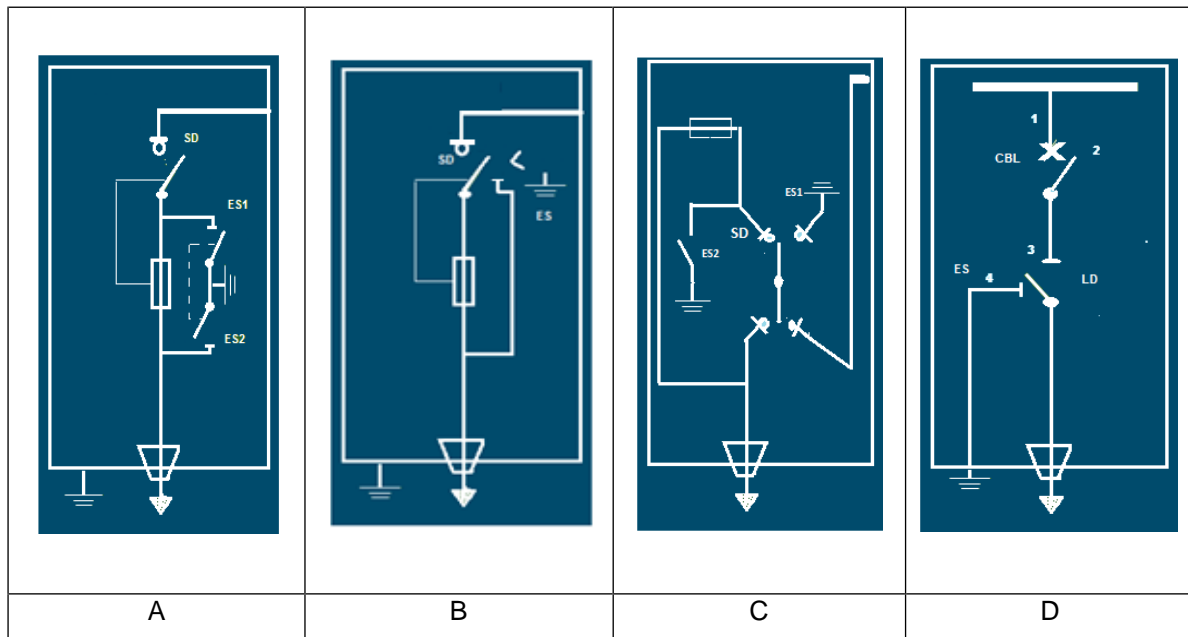
- 1 Switch-disconnector / Earthing switch (ES) with 3 positions (EARTHED - OPEN – CLOSED)

OPTION D: Configuration with

- Vacuum circuit-breaker (CBL) 2 position (CLOSED - OPEN)
- 3 position line-disconnector and earthing switch (CLOSED - OPEN – EARTHED)

Further single line diagrams could be proposed and implemented after Enel technical department approval.

Technical Specification code: GRI-GRI-MAT-E&C-0002

Version no.3 dated 03/10/2022

Subject: Enel Grids - GSM001 - Medium Voltage Gas Insulated Switchgears for secondary distribution substations

Application Areas

Perimeter: Global

Staff Function: -

Service Function: -

Business Line: Enel Grids

7.3.4 Line Functional Unit (L)

The three-pole switch-disconnector and earthing switches shall comply with IEC 62271-103 and IEC 62271-102 respectively.

The operating point of the earthing switch functionality shall be separated from the operating point of the switch-disconnector functionality and interlocked with it.

The movement of the blades of the switching devices shall be simultaneous.

The three-pole manual operating device of the switch-disconnectors shall be dead-center overcoming both in opening and closing, vertical, rotational, or translational movement (IEC 60447).

The operations shall be performed by applying a moment that does not exceed 200 Nm, and the opening and closing speed shall be independent of the action of the operator.

In case that switch-disconnectors and earthing switches are separated, the shaft of the earthing switch shall be mechanically interlocked with the shaft of the switch-disconnector.

7.3.4.1 Rated characteristics

The rated characteristics of the switch–disconnector and the earthing switch are shown in Table 4 and Table 7.

Switch-Disconnector			
Rated Voltage (U_r)	[kV]	24	36
Rated normal current (I_r)	[A]	630	
Rated short-time withstand current (I_k)	[kA]	16/20	
Rated peak withstand current (I_p)	[kA]	41,6/ 52	
Rated duration of short-circuit (t_k)	[s]	1	
Mechanical endurance class	M1		
Electrical endurance class	E3		
Rated breaking current	of a mainly active load	[A]	630
	of a no-load line	[A]	1,5 2
	of a no-load cable	[A]	16 20
	in case of earth fault	[A]	60
	with cable-charging in case of earth fault	[A]	40

Table 3 - Characteristics of the switch-disconnector for Lines Functional Unit

Technical Specification code: GRI-GRI-MAT-E&C-0002

Version no.3 dated 03/10/2022

Subject: Enel Grids - GSM001 - Medium Voltage Gas Insulated Switchgears for secondary distribution substations

Application Areas

Perimeter: Global

Staff Function: -

Service Function: -

Business Line: Enel Grids

Earthing Switch			
Rated Voltage (U_r)	[kV]	24	36
Rated short-time withstand current (I_k) and Rated establishment short circuit current (I_{ma})	[kA]	16/20	
Rated peak withstand current (I_p)	[kA]	41,6 / 52	
Rated duration of short-circuit (t_k)	[s]	1	
Mechanical endurance class	M0		
Electrical endurance class	E2		

Table 4 - Characteristics of the switch–disconnector and earthing switch in line unit
7.3.4.2 Line Functional unit front panel

The elements displayed on the front panel of the line unit shall be such as to make them easily visible, readable, and accessible.

The front panel is divided in three areas:

- Switch-disconnector operation area.
- Earthing switch operation area.
- Common area.

All three areas shall be the same vertical than the related cable compartment.

If the operation of the switchgear is vertically oriented, the order of the areas shall be, from top to bottom: Switch-disconnector operation area → Earthing switch operation area.

If the operation of the switchgear is horizontally oriented, the order of the areas shall be, from left to right: Switch-disconnector operation area → Earthing switch operation area.

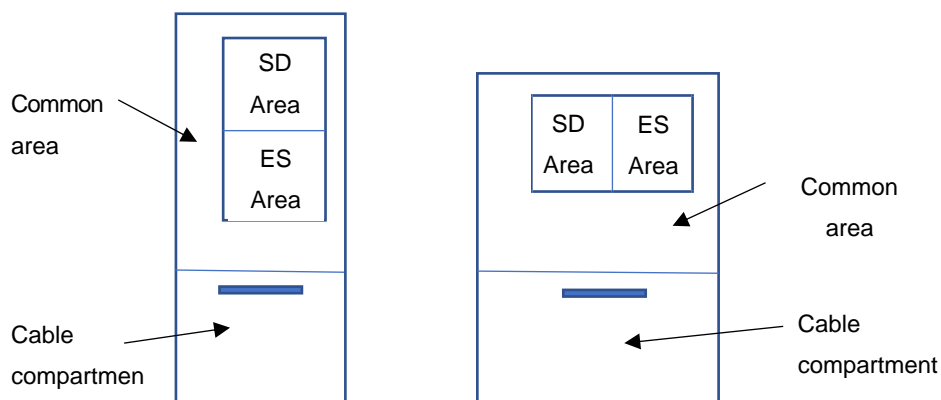
Figure 3 - Disposition of areas in the front panel in line unit

Subject: Enel Grids - GSM001 - Medium Voltage Gas Insulated Switchgears for secondary distribution substations

Application Areas

Perimeter: Global

Staff Function: -

Service Function: -

Business Line: Enel Grids

a) Switch-disconnector operation area.

The background of the switch-disconnector area shall be colored according to the RAL 5022-F2.

The switch-disconnector operation area is composed of the following elements:

- point for the operation of switch-disconnector, with indication of the operating directions in local language. The operating directions, according to IEC 60447, shall be displayed using the following colors:
 - Red 3000 RAL-F2 color corresponding to the close direction of the switch-disconnector.
 - Green 6017 RAL-F2 corresponding to the open direction of the switch-disconnector.

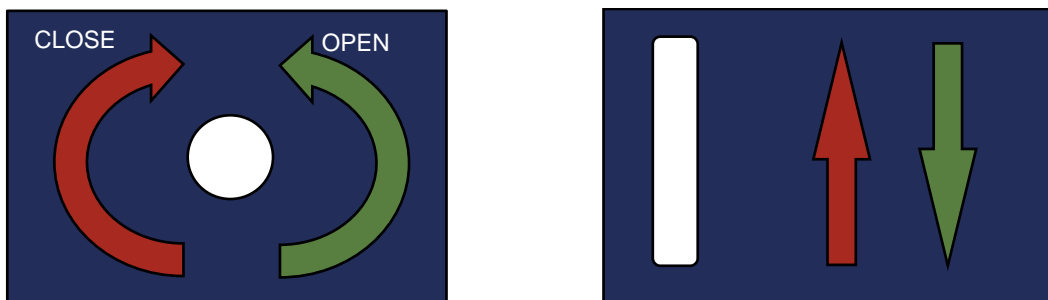

Figure 4 – Point for the operation of switch-disconnector in line functional unit

- Indicator showing the position of the switch-disconnector. The indicator shall be mechanically interconnected with the mobile power contacts and the position shall be displayed using the following symbols:
 - Black "I" letter on red background 3000 RAL-F2 corresponding to the closed position of the switch-disconnector.
 - Black "O" letter on green background 6017 RAL-F2 corresponding to the open position of the switch-disconnector.

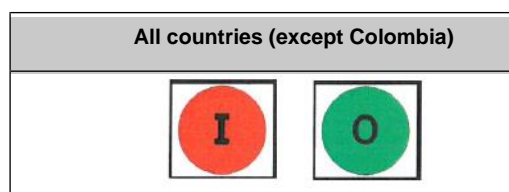

Figure 5 - Indicator for the position of the switch-disconnector in line functional unit

Technical Specification code: GRI-GRI-MAT-E&C-0002

Version no.3 dated 03/10/2022

Subject: Enel Grids - GSM001 - Medium Voltage Gas Insulated Switchgears for secondary distribution substations

Application Areas

Perimeter: Global

Staff Function: -

Service Function: -

Business Line: Enel Grids

For Colombia, the position shall be displayed using the following symbols:

- Black "I" letter on green background 6017 RAL-F2 corresponding to the closed position of the switch-disconnector.
- Black "O" letter on red background 3000 RAL-F2 corresponding to the open position of the switch-disconnector.

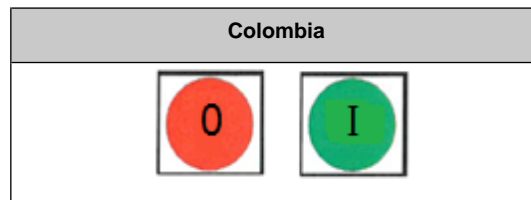

Figure 6 - Indicator for the position of the switch-disconnector in line unit (Colombia)

The indicators shall be visible even with the front panel removed.

The indicators shall be protected by a transparent window that prevents the entry of external objects to prevent its indication from being altered by external manipulation.

- Two buttons for the electrical opening (green) and closing (red) operations in case of switchgears with electric command. The buttons shall be protected to avoid accidental touch and shall have a nameplate indicating their performed function (open / close) in the language that corresponds to the Country in which the switchgear will be delivered.
- Switch to enable/disable the motorized electrical operation (both from local buttons and from remote control). The switch shall be lockable and will allow the insertion of a padlock with a shackle up to 6 mm in diameter. The lockable point shall be signaled by a “padlock” symbol. The switch shall have a nameplate indicating its function in the language that corresponds to the Country in which the switchgear will be delivered. In addition, next to the switch, there will be the indications O Off (motor disabled) and I ON (motor enabled).



Figure 7 - Example of switch to enable/disable the electrical operation in line functional unit

Application Areas

Perimeter: Global

Staff Function: -

Service Function: -

Business Line: Enel Grids

b) Earthing switch operation area

The background of the earthing switch area shall be colored according to RAL 1015-F2.

The earthing switch operation area is composed of the following elements:

- Point for operation of the earthing switch, with indication of the operating directions in local language. The operating directions, according to IEC 60447, shall be displayed using the following colors:
 - yellow color 1021 RAL-F2 corresponding to the close direction of the earthing switch.
 - gray color 7030 RAL-F2 corresponding to the open direction of the earthing switch.

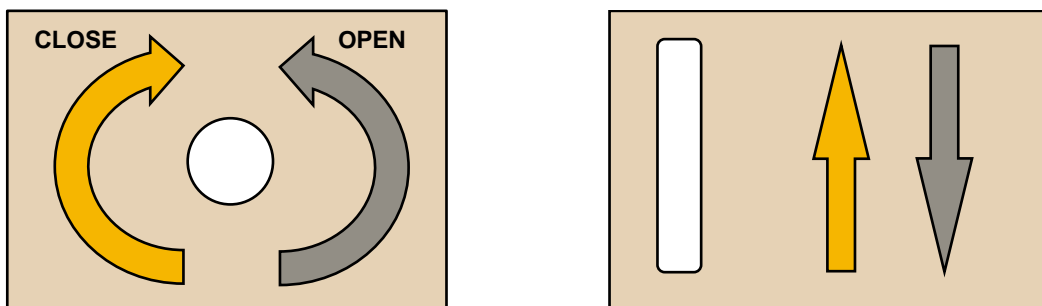

Figure 8 – Point for the operation of earthing switch in line functional unit

- Indicator showing the position of the earthing switch. The indicator shall be mechanically interconnected with the mobile power contacts and the position shall be displayed using the following symbols:
 - black "I" letter on yellow background 1021 RAL-F2 corresponding to the closed position of the earthing switch.
 - black "O" letter on gray background 7030 RAL-F2 corresponding to the open position of the earthing switch.

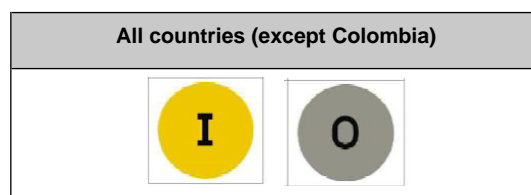

Figure 9 - Indicator for the position of the earthing switch in line functional unit

Technical Specification code: GRI-GRI-MAT-E&C-0002

Version no.3 dated 03/10/2022

Subject: Enel Grids - GSM001 - Medium Voltage Gas Insulated Switchgears for secondary distribution substations

Application Areas

Perimeter: Global

Staff Function: -

Service Function: -

Business Line: Enel Grids

For Colombia, the position shall be displayed using the following symbols:

- black "I" letter on green background 6017 RAL-F2 corresponding to the closed position of the switch-disconnector.
- black "O" letter on red background 3000 RAL-F2 corresponding to the open position of the switch-disconnector.

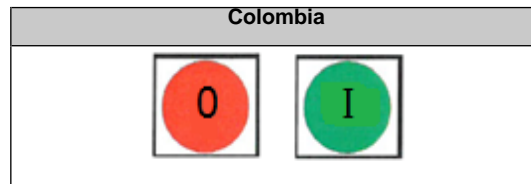

Figure 10 - Indicator for the position of the earthing switch in line functional unit (Colombia)

The indicators shall be visible even with the front panel removed.

The indicators shall be protected by a transparent window that prevents the entry of foreign objects to prevent its indication from being altered by external manipulation.

c) Common area

The common area of the front panel is the part of the front panel that contains the elements defined in the switch-disconnector area and the earthing switch area.

In the common area are located the following elements:

- Voltage detection system (VDS), according to §7.3.10
- Manometer, if necessary, according to §7.3.6
- Rating plate according to §7.3.18.1, if the line functional unit is modular. In case the line functional unit is a part of a compact RMU, the rating plate can be attached to any functional unit.
- Operating sequence nameplate, according to §7.3.18.2
- Synoptic scheme, according to §7.3.3
- Label holder, according to §7.3.18.4

**Technical Specification code: GRI-GRI-MAT-E&C-0002**

Version no.3 dated 03/10/2022

Subject: Enel Grids - GSM001 - Medium Voltage Gas Insulated Switchgears for secondary distribution substations**Application Areas**

Perimeter: Global

Staff Function: -

Service Function: -

Business Line: Enel Grids

7.3.4.3 Interlocking

The sequence of operations to close the line output shall be:

1. Opening of the earthing switch.
2. Closing the switch-disconnector.

The sequence of operations to open the line output in safe condition shall be:

1. Opening of the switch-disconnector.
2. Closing the earthing switch.

It will only be possible to operate the switch-disconnector when the earthing switch is in the open position and the access door of the cable compartment is closed. An electrical interlock will allow the motor to operate only when the earthing blades are completely open.

It will only be possible to operate the earthing switch when the switch-disconnector is in the open position and with the access door of the cable compartment closed.

The switch-disconnector and the earthing switch shall not be concurrently closed.

Two points shall be provided where a padlock can be inserted to lock the manual operation of the switch-disconnector and of the earthing switch in an independent way, in both open and closed positions. They will allow the insertion of a padlock with a shackle up to 6 mm in diameter. These points shall be signalized by a "padlock" symbol

It shall be possible to lock the electrical operation of the switch-disconnector through the switch indicated in Figure 7.

The insertion of the command lever in the switch-disconnector operation point or in the earthing switch operation point shall prevent the motorized operation of the switch-disconnector. This interlock must act before the end of the lever engages on the operating shaft. This condition can be achieved both with a mechanical mechanism (decoupling of the motor) or with an electric solution (cutting motor power supply).

The access door of the cable compartment shall be removed only in safe condition, with the switch-disconnector open and earthing switch closed. This condition shall be achieved with a mechanical interlock.

Technical Specification code: GRI-GRI-MAT-E&C-0002

Version no.3 dated 03/10/2022

Subject: Enel Grids - GSM001 - Medium Voltage Gas Insulated Switchgears for secondary distribution substations

Application Areas

Perimeter: Global

Staff Function: -

Service Function: -

Business Line: Enel Grids

With the access door removed, an electrical interlock shall prevent the electrical operation of the switch-disconnector and a mechanical interlock shall prevent the mechanical operation of both, the switch-disconnector, and the earthing switch.

For cable testing, with the access door removed, the interlock of the earthing switch may be bypassed only using a screwdriver. The mechanical and electrical interlock of the switch-disconnector must remain in any case. This bypass system must be designed in such a way that each time a closing operation of the earthing switch is executed, the interlock returns to its normal situation.

See §7.6 for the list of the interlocks checking.

7.3.5 Transformer Protection Functional Unit (T)

The manual switch-disconnector (SD) combined with fuses, for the MV / LV transformer protection, shall comply with IEC 62271-105 and IEC 62271-103

7.3.5.1 Rated characteristics

Switch-disconnector			
Rated Voltage (U_r)	[kV]	24	36
Rated normal current (I_r)	[A]	200	
Rated short-time withstand current (I_k)	[kA]	16/20	
Rated peak withstand current (I_p)	[kA]	41,6/52	
Rated duration of short-circuit (t_k)	[s]	1	
Mechanical endurance class	M1		
Electrical endurance class	E3		
Transfer Current ($TD_{transfer}$)	A	800	

Table 5 - Characteristics of the switch–disconnector for T functional unit

Technical Specification code: GRI-GRI-MAT-E&C-0002

Version no.3 dated 03/10/2022

Subject: Enel Grids - GSM001 - Medium Voltage Gas Insulated Switchgears for secondary distribution substations

Application Areas

Perimeter: Global

Staff Function: -

Service Function: -

Business Line: Enel Grids

Earthing switches ES1 or ES (see Figure 2)			
Rated Voltage (U_r)	[kV]	24	36
Rated short-time withstand current (I_k) and Rated establishment short circuit current (I_{ma})	[kA]	16/20	
Rated peak withstand current (I_p)	[kA]	41,6/52	
Rated duration of short-circuit (t_k)	[s]	1	
Mechanical endurance class	M0		
Electrical endurance class	E2		
Earthing switch ES2 (see Figure 2)			
Rated Voltage (U_r)	[kV]	24	36
Rated short-time withstand current (I_k) and Rated establishment short circuit current (I_{ma})	[kA]	1	
Rated peak withstand current (I_p)	[kA]	2,5	
Rated duration of short-circuit (t_k)	[s]	1	
Mechanical endurance class	M0		
Electrical endurance class	E2		

Table 6 - Characteristics of the earthing switch for T functional unit

Technical Specification code: GRI-GRI-MAT-E&C-0002

Version no.3 dated 03/10/2022

Subject: Enel Grids - GSM001 - Medium Voltage Gas Insulated Switchgears for secondary distribution substations

Application Areas

Perimeter: Global

Staff Function: -

Service Function: -

Business Line: Enel Grids

Circuit Breaker			
Rated Voltage (U_r)	[kV]	24	36
Rated normal current (I_r)	[A]	200	
Rated short circuit breaking current (I_{sc})	[kA]	16/20	
First-pole-to-clear factor (K_{pp})	-	1,3 and 1,5	
Circuit breaker class	S1		
Rated peak withstand current (I_p)	[kA]	41,6/ 52	
Rated duration of short-circuit (t_k)	[s]	1	
Mechanical endurance class	M1		
Electrical endurance class	E1		
Line disconnecter:			
Rated normal current	[A]	630	
Rated short-time withstand current	[kA]	16/20	
Rated peak withstand current	[kA]	41,6/52	
Rated duration of short-circuit	[s]	1	
Mechanical endurance class	M0		
Earthing switches:			
Rated short-time withstand current	[kA]	1	
Rated peak withstand current	[kA]	2,5	
Mechanical endurance class	M0		
Electrical endurance class	E2		

Table 7 - Characteristics of the circuit breaker in transformer protection functional unit

To show the open position of the switch-disconnector, a micro-switch shall be provided. This micro-switch shall be put inside the operating device protective shell and shall be able to switch small currents.

This micro-switch shall be connected to a 2x1.5 mm² LV cable with a length of 8 m that protrudes from the switchgear. This cable should be correspondingly identified.

Technical Specification code: GRI-GRI-MAT-E&C-0002

Version no.3 dated 03/10/2022

Subject: Enel Grids - GSM001 - Medium Voltage Gas Insulated Switchgears for secondary distribution substations

Application Areas

Perimeter: Global

Staff Function: -

Service Function: -

Business Line: Enel Grids

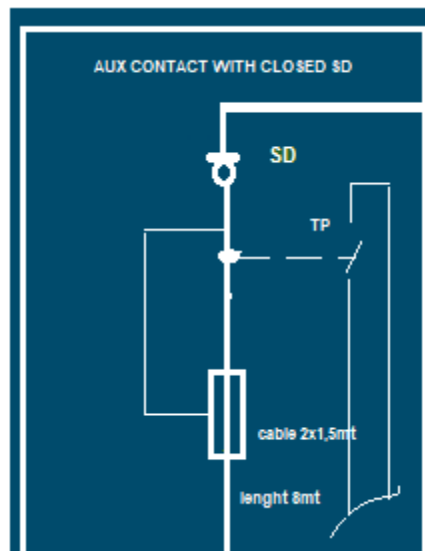

Figure 11 - wiring LV diagram between T and UP cells

The connection must have a faston with cable end sleeves as shown in Figure 12.



Figure 12 – Faston with cable end sleeves

7.3.5.2 Transformer protection functional unit front panel

The elements displayed on the front panel of the transformer protection functional unit shall be such as to make them easily visible, readable, and accessible.

The front panel is divided in three areas:

- a) Switch-disconnector operation area.
- b) Earthing switch operation area.
- c) Common area.

All three areas shall be the same vertical than the related cable compartment.

If the operation of the switchgear is vertically oriented, the order of the areas shall be, from top to bottom:
Switch-disconnector operation area → Earthing switch operation area.

Application Areas

Perimeter: Global

Staff Function: -

Service Function: -

Business Line: Enel Grids

If the operation of the switchgear is horizontally oriented, the order of the areas shall be, from left to right: Switch-disconnector operation area → Earthing switch operation area.

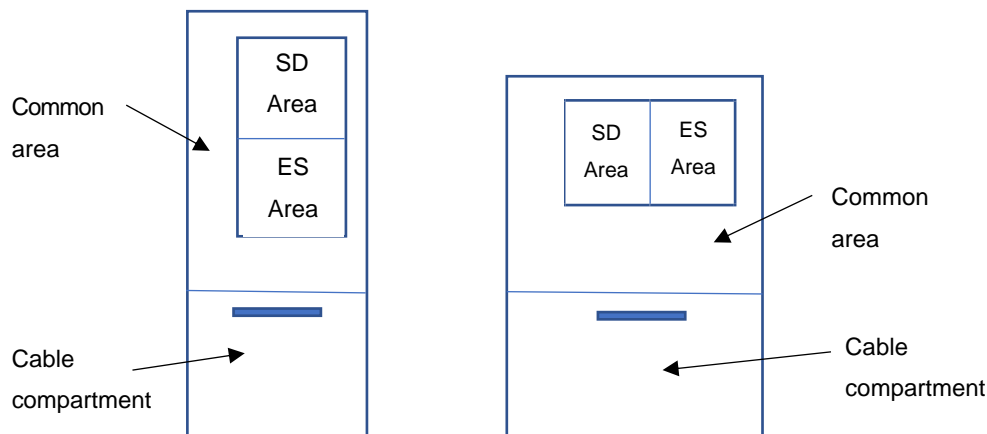

Figure 13 - Disposition of areas in the front panel in transformer protection functional unit

b) Switch-disconnector operation area.

The background of the switch-disconnector area shall be colored according to the RAL 5022-F2.

The switch-disconnector operation area is composed of the following elements:

- point for the operation of switch-disconnector/spring charger, with indication of the operating directions in local language. The operating directions, according to IEC 60447, shall be displayed using the following colors:
 - Red 3000 RAL-F2 color corresponding to the close direction of the switch-disconnector.
 - Green 6017 RAL-F2 corresponding to the open direction of the switch-disconnector.

Technical Specification code: GRI-GRI-MAT-E&C-0002

Version no.3 dated 03/10/2022

Subject: Enel Grids - GSM001 - Medium Voltage Gas Insulated Switchgears for secondary distribution substations

Application Areas

Perimeter: Global

Staff Function: -

Service Function: -

Business Line: Enel Grids

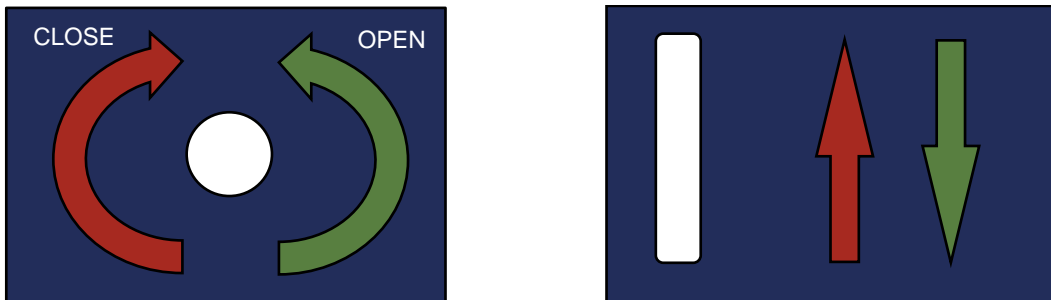

Figure 14 – Point for the operation of switch-disconnector in line functional unit

The opening of the switch-disconnector by means of release spring energy device is also accepted.

Other alternative operation solutions based on buttons could be considered subject to Enel approval.

- Indicator showing the position of the switch-disconnector. The indicator shall be mechanically interconnected with the mobile power contacts and the position shall be displayed using the following symbols:

- Black "I" letter on red background 3000 RAL-F2 corresponding to the closed position of the switch-disconnector.
- Black "O" letter on green background 6017 RAL-F2 corresponding to the open position of the switch-disconnector.

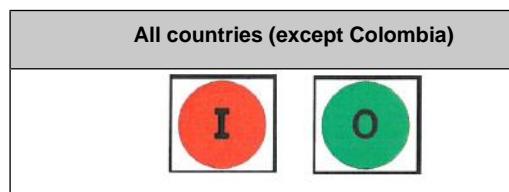

Figure 15 - Indicator for the position of the switch-disconnector in line functional unit

For Colombia, the position shall be displayed using the following symbols:

- Black "I" letter on green background 6017 RAL-F2 corresponding to the closed position of the switch-disconnector.
- Black "O" letter on red background 3000 RAL-F2 corresponding to the open position of the switch-disconnector.

Technical Specification code: GRI-GRI-MAT-E&C-0002

Version no.3 dated 03/10/2022

Subject: Enel Grids - GSM001 - Medium Voltage Gas Insulated Switchgears for secondary distribution substations

Application Areas

Perimeter: Global

Staff Function: -

Service Function: -

Business Line: Enel Grids

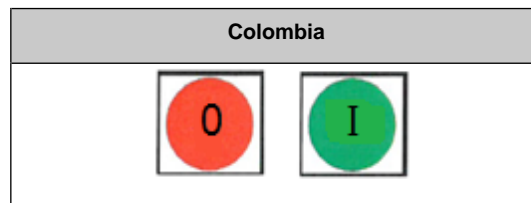

Figure 16 - Indicator for the position of the switch-disconnector in line unit (Colombia)

The indicators shall be visible even with the front panel removed.

The indicators shall be protected by a transparent window that prevents the entry of external objects to prevent its indication from being altered by external manipulation.

b) Earthing switch operation area

The background of the earthing switch area shall be colored according to RAL 1015-F2.

The earthing switch operation area is composed of the following elements:

- Point for operation of the earthing switch, with indication of the operating directions in local language. The operating directions, according to IEC 60447, shall be displayed using the following colors:
 - yellow color 1021 RAL-F2 corresponding to the close direction of the earthing switch.
 - gray color 7030 RAL-F2 corresponding to the open direction of the earthing switch.

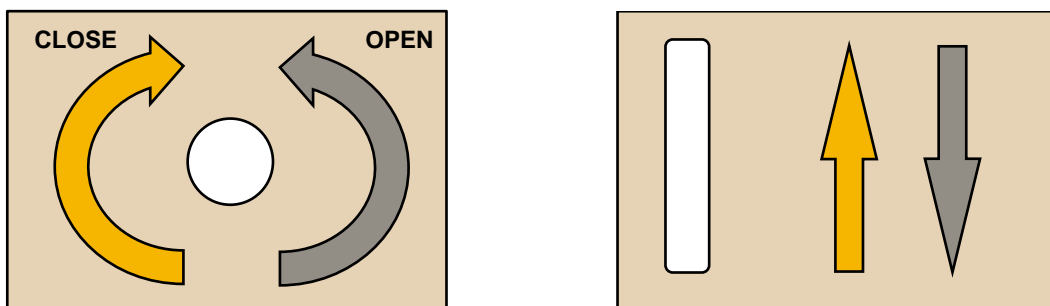

Figure 17 – Point for the operation of earthing switch in line functional unit

- Indicator showing the position of the earthing switch. The indicator shall be mechanically interconnected with the mobile power contacts and the position shall be displayed using the following symbols:

Technical Specification code: GRI-GRI-MAT-E&C-0002

Version no.3 dated 03/10/2022

Subject: Enel Grids - GSM001 - Medium Voltage Gas Insulated Switchgears for secondary distribution substations

Application Areas

Perimeter: Global

Staff Function: -

Service Function: -

Business Line: Enel Grids

- black "I" letter on yellow background 1021 RAL-F2 corresponding to the closed position of the earthing switch.
- black "O" letter on gray background 7030 RAL-F2 corresponding to the open position of the earthing switch.

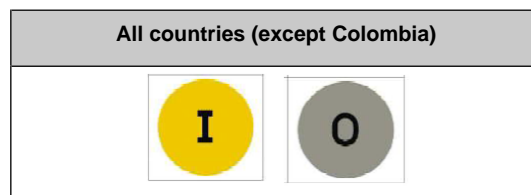

Figure 18 - Indicator for the position of the earthing switch in line functional unit

For Colombia, the position shall be displayed using the following symbols:

- black "I" letter on green background 6017 RAL-F2 corresponding to the closed position of the switch-disconnector.
- black "O" letter on red background 3000 RAL-F2 corresponding to the open position of the switch-disconnector.

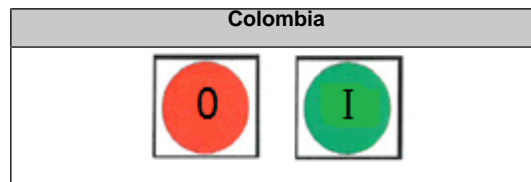

Figure 19 - Indicator for the position of the earthing switch in line functional unit (Colombia)

The indicators shall be visible even with the front panel removed.

The indicators shall be protected by a transparent window that prevents the entry of foreign objects to prevent its indication from being altered by external manipulation.

Subject: Enel Grids - GSM001 - Medium Voltage Gas Insulated Switchgears for secondary distribution substations

Application Areas

Perimeter: Global

Staff Function: -

Service Function: -

Business Line: Enel Grids

c) Common area

The common area of the front panel is the part of the front panel that contains the elements defined in the switch-disconnector area and the earthing-switch area.

In the common area are located the following elements:

- Fuse status indicator, with the following symbols:
 - Green indicator: Meaning all the fuses are ok
 - Red Indicator: Meaning one or more fuses blew.

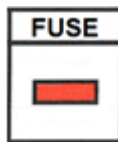

Figure 20 - Example of indicator showing one or more blew fuses

The fuse indicator shall be protected by a transparent window that prevents the entry of foreign objects to prevent its indication from being altered by external manipulation.

- Voltage detection system (VDS), according to §7.3.10
- Manometer, if necessary, according to §7.3.6.
- Rating plate according to §7.3.18.1, if the transformer unit is modular. In case the transformer unit is a part of a compact RMU, the rating plate can be attached to any functional unit.
- Operating sequence nameplate, according to §7.3.18.2
- Synoptic scheme, according to §7.3.3
- Label holder, according to chapter §7.3.18.4

**Technical Specification code: GRI-GRI-MAT-E&C-0002**

Version no.3 dated 03/10/2022

Subject: Enel Grids - GSM001 - Medium Voltage Gas Insulated Switchgears for secondary distribution substations**Application Areas**

Perimeter: Global

Staff Function: -

Service Function: -

Business Line: Enel Grids

7.3.5.3 Interlocking

The sequence of operations to close the transformer output feeder shall be:

1. Opening of the earthing switches.
2. Closing the switch-disconnector.

The sequence of operations to open the transformer output feeder (safe condition) shall be:

1. Opening of the switch-disconnector.
2. Closing the earthing switches.

It will only be possible to operate the switch-disconnector when the earthing switches are in the open position and with the access door of the cable compartment and the transformer fuse compartment closed.

It will only be possible to operate the earthing switches when the switch-disconnector is in the open position and with the access door of the cable compartment and the transformer fuse compartment closed.

The switch-disconnector and the earthing switches shall not be concurrently closed.

Two points shall be provided where a padlock can be inserted to lock the operation of the switch-disconnector and of the earthing switches in an independent way, in both open and closed positions. They will allow the insertion of a padlock with a shackle up to 6 mm in diameter. These points should be signaled by a "padlock" symbol.

The access door of the cable compartment and the transformer fuse compartment shall be removed only in safe condition, with the switch-disconnector open and earthing switches closed. This condition shall be achieved with a mechanical interlock.

When the switch-disconnector is opened for fuse tripping, the switch-disconnector shall be ready to do the spring charging and the closing operation in one single maneuver, without intermediate operations

Melting of one or more fuses shall cause the opening of the switch-disconnector.

See §7.6 for the list of the interlocks checking.

Technical Specification code: GRI-GRI-MAT-E&C-0002

Version no.3 dated 03/10/2022

Subject: Enel Grids - GSM001 - Medium Voltage Gas Insulated Switchgears for secondary distribution substations

Application Areas

Perimeter: Global

Staff Function: -

Service Function: -

Business Line: Enel Grids

7.3.5.4 Fuse-carrier and fuses

The fuse-carrier is composed by a container made of insulating material having an appropriate closing device that ensures the protection against dust pollutants with a degree of protection IP4X.

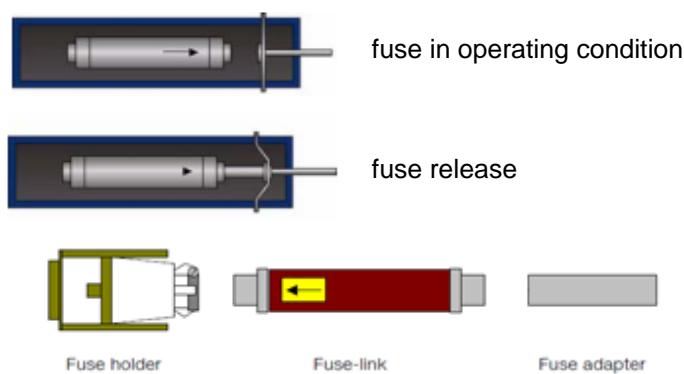

Figure 21 – Fuse and operation scheme

The MV fuse holder, which shall be protected by a metal compartment, can be installed inside the cable compartment or outside the gas-filled compartment.

The opening of the fuse-holder shall always happen at a pressure which is not dangerous for the operator. The opening of the fuse-holder shall be made in two steps, one step that breaks the tightness and releases any possible overpressure, keeping the fuse mechanically attached to the switchgear, and a second step that releases the fuse and allows its complete extraction.

The fuse-carrier shall have dimensions that are suitable to the use of fuses with maximum rated voltage of 12 kV, 17.5 kV, 24 kV and 36 kV. In case of fuses with a rated voltage other than 24 kV or 36 kV, an appropriate adapter shall be provided.

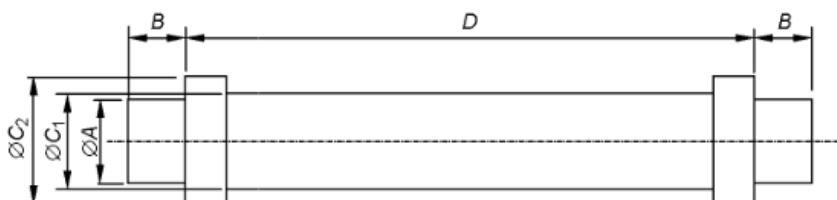

Figure 22 – Fuse-link dimensions

The striker shall be on the center-line of the fuse-link.

Technical Specification code: GRI-GRI-MAT-E&C-0002

Version no.3 dated 03/10/2022

Subject: Enel Grids - GSM001 - Medium Voltage Gas Insulated Switchgears for secondary distribution substations

Application Areas

Perimeter: Global

Staff Function: -

Service Function: -

Business Line: Enel Grids

V	$\varnothing A$	B	$\varnothing C_2$ <i>min.</i>	$\varnothing C_1$ and C_2 <i>max.</i>	–
7,2 12 17,5 24 36	45 ± 1	+	50	88	192 292 367 442 537

Table 8 - Dimensions of fuses

Dimensions in millimeters

The removal and replacement of fuses shall be made without using any tools, insulating greases or similar products.

Guide discs or similar accessories independents of the fuse container are not allowed. Any guide discs shall be fixed to the fuse tube itself.

The kinematics of the fuse-carrier, where the striker acts for the opening of the switch-disconnector, shall be made to be operated independently from the striker's diameter and, in any case, up to a maximum of 20 mm and should be compatible with medium type strikers described in IEC 60282-1.

The fuse holder contacts shall be spring-loaded silver plated or nickel plated.

The maximum rated current of the fuses shall be 100 A for 24 kV and 63 A for 36 kV.

7.3.5.5 Circuit Breaker

If a vacuum circuit breaker is used for the transformer module, it shall comply with the GSCM004 specification and IEC 62271-100. The characteristics of the circuit breaker are shown in Table 7.

The circuit breaker shall operate in systems with insulated neutral and systems with effectively earthed neutral.

In addition, a protective relay with three current transformers shall be installed. The current transformers shall be installed on the cable prior to the installation of the cable termination. The settings for the time-current characteristics of the protective relay shall be as close as possible to the time-current characteristics of the 10-24kV, 25A, 40A, 63A and 100A fuses.

Technical Specification code: GRI-GRI-MAT-E&C-0002

Version no.3 dated 03/10/2022

Subject: Enel Grids - GSM001 - Medium Voltage Gas Insulated Switchgears for secondary distribution substations

Application Areas

Perimeter: Global

Staff Function: -

Service Function: -

Business Line: Enel Grids

The relay's integrated self-diagnostic system shall continuously monitor the status of the relay hardware and the operation of the relay software. When a relay fault is detected, a red-colored loop should light up. In the event of a critical relay fault, all protective functions of the relay shall be completely blocked to prevent any incorrect operation of the relay. The relay must not open the switch if the protection fails. If a high fault current is present with a faulty relay, the circuit breaker must be able to trip.

The current transformer shall be able to accommodate a 50 mm diameter cable.

The relay shall be self-powered and not connected to the grid.

Alternative solutions for circuit breaker transformer protection could be considered.

7.3.5.6 Trip coil (Only for Spain)

The transformer protection functional unit shall be equipped with a release coil. The coil shall operate with 230Vca and perform correctly between 85% and 110% of that voltage. The coil shall be put inside the operating device protective shell and can be connected from the outside feeder circuit in a terminal block located under the removable front panel, jointly at the switch-disconnector status micro-switch connection.

This terminal block shall be properly identified, and its replacement shall be possible without service interruption.

The coil circuit shall have an insulation level, towards the earthed metallic parts of the switchgear, of 10kV (1 minute) at short-duration power-frequency withstand voltage and 20kV to lightning impulse withstand voltage (1,2/50 μ)

It shall be possible to replace the coil with the switchgear in service.

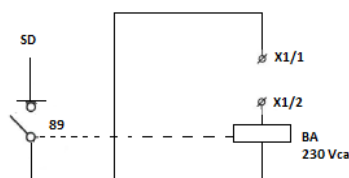

Figure 23 - Electric diagram of coil connection

The manufacturer shall clearly indicate in the switchgear manual how the connection between outside feeder circuit and the trip coil shall be made.

Subject: Enel Grids - GSM001 - Medium Voltage Gas Insulated Switchgears for secondary distribution substations

Application Areas

Perimeter: Global

Staff Function: -

Service Function: -

Business Line: Enel Grids

7.3.6 Manometer

To verify an acceptable pressure level of SF₆, a manometer shall be provided.

There shall be one manometer for each independent SF₆ gas-filled compartment that integrates the switchgear.

The manometer shall be non-extractable, and, in normal conditions, the pressure indication shall be between 25% and 75% of the area marked as safe. The area marked as safe shall be green RAL 6017 whereas the other area shall be red RAL 3000.

The manometer will be mounted on the common area of the front panel and will be clearly visible under normal operating conditions.



Figure 24 – Example of manometer

As an alternative to the pressure manometer, magnetic indicators can be used to measure the gas level.

7.3.7 Earth connections

The earth of the switchgear shall be made with a copper wire whose cross-section shall not be less than 50 mm².

The operating shafts of the switch-disconnectors and earthing switches shall be connected to the earth (with conductors whose cross-section shall not be less than 30 mm²) and to the other metallic objects. This connection is not necessary if the switchgear internal shaft is made of insulating material.

From the earthing point of the switchgear a copper bar with cross-section not less than 50 mm², running the entire length of the switchgear, shall be provided. In addition, M12 bolts shall be provided onto the bar in the line functional unit and transformer functional unit, to connect the earth screen of the MV cable accessories. It shall be possible to connect to the copper bar to the substation's grounding system from both sides of the external part of the switchgear, i.e., two M12 bolts shall be provided.

To remove the copper bar, it shall not be necessary to disassemble, totally or partially, the switchgear by inserting or removing a cable and its corresponding connector.

Technical Specification code: GRI-GRI-MAT-E&C-0002

Version no.3 dated 03/10/2022

Subject: Enel Grids - GSM001 - Medium Voltage Gas Insulated Switchgears for secondary distribution substations

Application Areas

Perimeter: Global

Staff Function: -

Service Function: -

Business Line: Enel Grids

The earthing points on the outside of the switchgear shall have an earthing symbol.



Figure 25 – Earth connections

7.3.8 Design requirement for installation

The switchgear shall be fixed to the floor through M12 screws.

The switchgear shall be able to be installed and operate correctly even with a floor unevenness up to 5 millimeters per meter, both longitudinally and transversely.



Figure 26 – Floor fixing example

7.3.9 Cable compartments

For each line functional unit and each transformer protection functional unit single-core steel supports or insulating supports, suitable for the installation of MV cables in a vertical plane, shall be provided. The separable connectors will be according to GSCC006. In case of metallic supports induced current shall be avoided.

For Line Functional Units it shall be possible to install T Separable Connector according to GSCC006.

For Transformer protection functional unit, it shall be possible to install elbow separable connector according to GSCC006.

The installation height of the supports shall be at least 450 mm from the connector.

Technical Specification code: GRI-GRI-MAT-E&C-0002

Version no.3 dated 03/10/2022

Subject: Enel Grids - GSM001 - Medium Voltage Gas Insulated Switchgears for secondary distribution substations

Application Areas

Perimeter: Global

Staff Function: -

Service Function: -

Business Line: Enel Grids

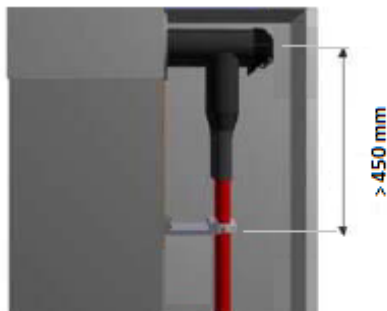

Figure 27 – Examples height of the supports

Cable supports shall be suitable for installation cables with cross-section ranges from 50 mm² to 630 mm², according to GSC001.

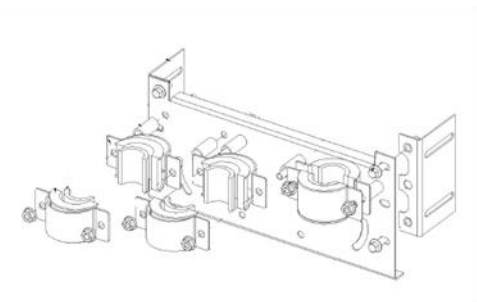

Figure 28 - Examples of Supports and Separable connectors installation

The identification of the phases of each bushing shall be carried out using labels according to Table 8 and Figure 29.

Destination country	Marking of the phases
Colombia	L1 – L2 - L3
Chile	L1 – L2 - L3
Brazil	L1 – L2 - L3
Spain	L1 – L2 - L3
Peru	L1 – L2 - L3
Italy	L1 – L2 - L3
Romania	L1 – L2 - L3
Argentina	R – S - T

Table 8 – Phase designation

Technical Specification code: GRI-GRI-MAT-E&C-0002

Version no.3 dated 03/10/2022

Subject: Enel Grids - GSM001 - Medium Voltage Gas Insulated Switchgears for secondary distribution substations

Application Areas

Perimeter: Global

Staff Function: -

Service Function: -

Business Line: Enel Grids



Figure 29 – Marking of the phases

The access door to the cable compartment shall not be bolted.

7.3.10 Voltage detecting systems

For each functional unit, LRM voltage detection system (VDS) compliant with IEC 61243-5 shall be installed to check voltage presence of the feeders. For this scope, VDIS compliant with IEC 62271-213 are accepted as well.

The identification of the phases on the VDS shall be carried out using labels according to Table 8

For all RMU an additional Busbar VDS compliant with §7.9 shall be provided.

The capacitive voltage divider could be positioned on top of the busbar or laterally (e.g., by using proper busbar extension devices such as plug-in units for coupling modular units), preferably on the transformer protection functional unit. If such functional unit is not required, the Busbar VDS shall be installed on the upper part of the front panel of the second line functional unit (starting from the left).

The Busbar VDS shall be provided without the voltage free lamps.

The busbar bushings shall be covered to be protected against direct contacts.



Figure 30 – Bushing of the capacitive voltage divider and connection of the busbar VDS (not bidding).

Technical Specification code: GRI-GRI-MAT-E&C-0002

Version no.3 dated 03/10/2022

Subject: Enel Grids - GSM001 - Medium Voltage Gas Insulated Switchgears for secondary distribution substations

Application Areas

Perimeter: Global

Staff Function: -

Service Function: -

Business Line: Enel Grids

VDS shall be clearly identified in every single functional unit, surrounded by a box with the words “Busbar Side” or “Cable Side” in Local language.

Language	BUSBAR SIDE	CABLE SIDE
Italian	LATO SBARRE	LATO CAVI
Spanish	LADO BARRAS	LADO CABLES
Portuguese	LADO BARRA	LADO CABO
Romanian	LATERAL BARE	LATERAL CABLU

Table 9 – VDS/VDIS Designation

VDIS (VDS) for $U_r=24\text{kV}$ switchgears shall have an U_n (Rated Voltage) range equal to 6-22 kV.

VDIS (VDS) for $U_r=36\text{kV}$ switchgears shall have a U_n (Rated Voltage) range equal to 22-33kV.

The following markings shall be legibly fixed to the interface, in characters at least 3 mm high:

- Capacitive interface symbol (according to IEC 61243-5).
- LRM/VDIS interface symbol
- On each interface: phase designation and earth symbol (according to IEC 61243-5).

The VDS/VDIS shall be accompanied by documentation indicated in IEC 61243-5 or 62271-213.

7.3.11 Low Power voltage Transformers

As indicated in §7.3.1 for each phase of the line functional unit LPVT shall be provided.

The connection cables, one per phase for each line functional unit, and the related connectors, considered an integral part of the LPVT, shall be compliant with GSCT005. Such cables shall be integrated within the switchgear, going out in the upper part of the equipment, i.e., near the RGDAT/RGDM support, with enough length to perform the connection (cables shall protrude from the upper part by at least 30 cm).

The secondary terminations of the LPVT, intended to be grounded, shall be connected to the switchgear ground inside it.

7.3.12 Support for the fault detector device (RGDM/RGDAT) and cable duct.

In the upper part of each line functional unit a support shall be provided for the fault detector device (as shown in Figure 31), located in its same vertical projection. These supports shall be external and shall allow the removal of the command protection shell without being taken.

Technical Specification code: GRI-GRI-MAT-E&C-0002

Version no.3 dated 03/10/2022

Subject: Enel Grids - GSM001 - Medium Voltage Gas Insulated Switchgears for secondary distribution substations

Application Areas

Perimeter: Global

Staff Function: -

Service Function: -

Business Line: Enel Grids

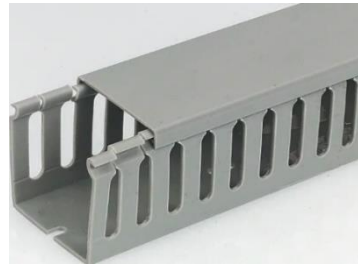
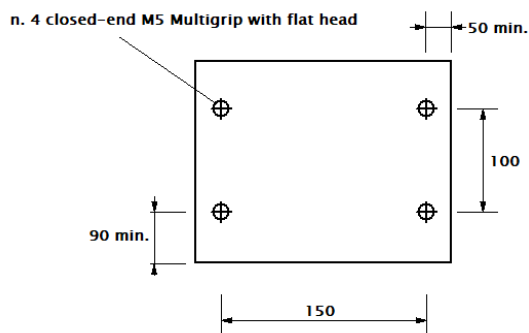

Figure 31 – Support for fault detector device and cable duct

Furthermore, in the upper part of the switchgear, a cable duct shall be provided for the external wiring of the cables that connect the motor and the fault detector (RDGM/RGDAT) to the RTU.

7.3.13 Command lever

During the operations, the end of the command lever shall not stick out from the two sides of the switchgear.

The command lever shall be made in steel, treated with electrolytic zinc-plating according to ISO 2081 (FZn 12 III) standard. It shall be stamped with the name of the manufacturer preferably with molding or, in any case, with a permanent indelible solution.

7.3.14 Switchgear dimensions

The maximum overall dimensions shall comply with Table 10.

Technical Specification code: GRI-GRI-MAT-E&C-0002

Version no.3 dated 03/10/2022

Subject: Enel Grids - GSM001 - Medium Voltage Gas Insulated Switchgears for secondary distribution substations

Application Areas

Perimeter: Global

Staff Function: -

Service Function: -

Business Line: Enel Grids

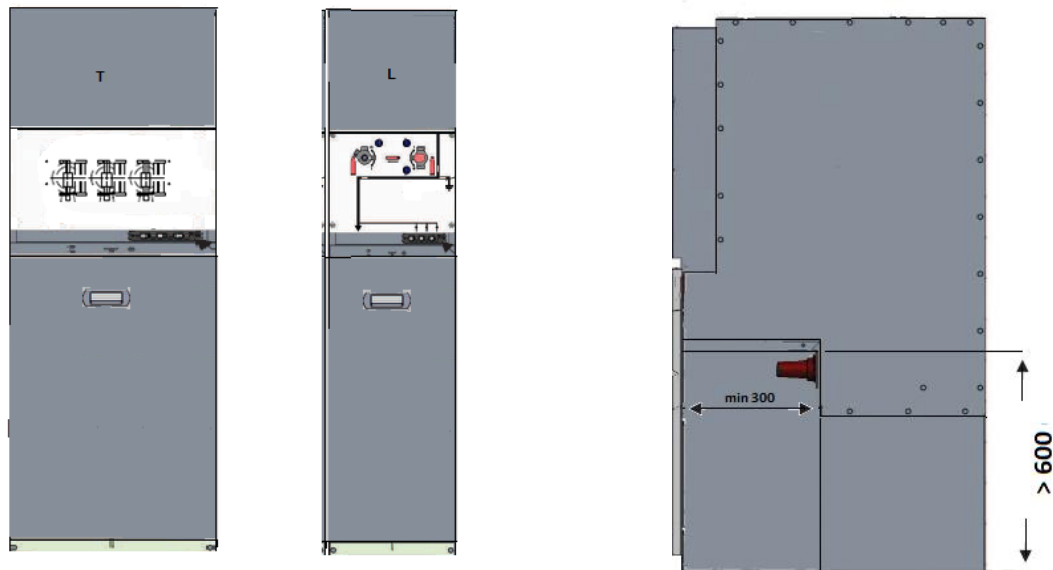

Functional Unit	Max Width [mm] 24 kV	Max Width [mm] 36 kV	Max Depth [mm] 24 kV**	Max Depth [mm] 36 kV*	Max Height [mm]*
Transformer	520	600	900	1100	2000
Line	400	450	900	1100	2000

Table 10 – Overall dimensions

* Including fault detector (RGDM/RGDAT) support.

** Including the free space required between the switchgear and the rear wall.

The height from the floor level to the lowest operation point shall be at least 1,0 m.

Dimensions other than those shown in Table 10 could be accepted after evaluation by Enel.

7.3.15 Modular MV switchgears

The modular functional units (1L and 1T) shall be equipped with busbar extension consisting of a contact coupling, e.g screened silicone coupling, to allow extension from both sides.

The functional units will connect each other through insulated connectors. IP3X degree of protection between assembled modular switchgears shall be ensured. All connection accessories will be part of the supply.

Technical Specification code: GRI-GRI-MAT-E&C-0002

Version no.3 dated 03/10/2022

Subject: Enel Grids - GSM001 - Medium Voltage Gas Insulated Switchgears for secondary distribution substations

Application Areas

Perimeter: Global

Staff Function: -

Service Function: -

Business Line: Enel Grids

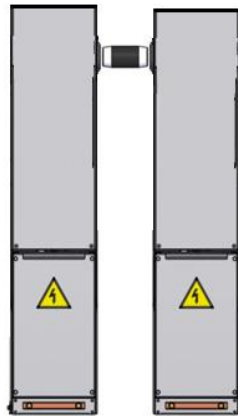

Figure 32 – Extensible modular units

7.3.16 Compact modules 5L+1T

The compact module 5L+1T shall be supplied in the following composition 3L and 2L+1T.

The equipment shall be supplied unpacked on two platforms and assembly shall take place on site.

The equipment shall be fitted with extension terminations on the sides of the units to allow for coupling (as per modular units).

7.3.17 Protective coating

7.3.17.1 Basic protection

The metal carpentry shall be painted with a paint conforming to series ISO 12944 and for corrosivity class C3 and durability HIGH.

No manual painting process is allowed.

To check the performance of the painting system and the behavior to corrosion, a test according to IEC 60068-2-52 with method 5 shall be performed.

As an alternative it is possible to use pre-galvanized steel type EN 10346 with coating thickness > 200 [g / m²] except for the cable compartment door and front panel. In any case the type test indicated above shall be performed.

The ferrous parts of the operating controls shall be protected by an electrolytic coating of at least 9 μm of zinc, or alternatively in stainless steel.

Technical Specification code: GRI-GRI-MAT-E&C-0002

Version no.3 dated 03/10/2022

Subject: Enel Grids - GSM001 - Medium Voltage Gas Insulated Switchgears for secondary distribution substations

Application Areas

Perimeter: Global

Staff Function: -

Service Function: -

Business Line: Enel Grids

Mounting nuts and bolts and small accessories, unless otherwise specified, shall be protected with electrolyte zinc Fe III Zn EN ISO 4042.

7.3.17.2 High protection

For high pollution environments metal carpentry shall be painted with a paint conforming to ISO 12944 and for corrosivity class C5, durability HIGH.

To check the performance of the painting system and the behavior to corrosion, a test according to IEC 60068-2-52 with method 6 shall be performed.

Alternative solutions/tests to demonstrate the equivalent suitability in this kind of environment can be proposed by the manufacturer and are subject to Enel approval.

7.3.18 Nameplates

7.3.18.1 Rating plate and fluorinated gases plate

The switchgear shall be provided with a rating plate containing the information according to IEC 62271-200. In addition to such information Enel Material code and type code shall be indicated.

The plate shall be made of anodized aluminum or adhesive printed with a laser printer and shall be durable and clearly legible under service conditions.

For SF6 insulated switchgears, following the European regulation regarding fluorinated greenhouse gases, the switchgear will include nameplates that comply in number, content, position, and characteristics with:

- Regulation (EU) No 517/2014 of the European Parliament and of the Council of 16 April 2014 on fluorinated greenhouse gases and repealing Regulation (EC) No 842/2006
- Commission Implementing Regulation (EU) 2015/2068 of 17 November 2015 establishing, pursuant to Regulation (EU) No 517/2014 of the European Parliament and of the Council, the format of labels for products and equipment containing fluorinated greenhouse gases.

7.3.18.2 Operating sequence nameplates and synoptic scheme

The switchgears shall be equipped with an operating sequence nameplate on which the sequence of operations to be executed shall be reported, respectively (in local language): close line / transformer output (switch-disconnector closed), the sequence open line / transformer output (safe condition) and

Technical Specification code: GRI-GRI-MAT-E&C-0002

Version no.3 dated 03/10/2022

Subject: Enel Grids - GSM001 - Medium Voltage Gas Insulated Switchgears for secondary distribution substations

Application Areas

Perimeter: Global

Staff Function: -

Service Function: -

Business Line: Enel Grids

sequence to access to the fuses (if applicable).

In addition, a label with the operating sequence in the cable compartment, clearly visible with the access panel removed, indicating the sequence for setting the cable test (showing the sequence of the opening of the earthing switch with the cable compartment access door removed).

The synoptic scheme of each single functionality (transformer protection or line functional units) shall be displayed and shall be positioned in the front panel part of each unit, so that it is clearly visible under service condition.

7.3.18.3 Warning nameplate against switchgear drilling

Each switchgear shall have circular nameplates, visible from all accessible sides during service, indicating the prohibition to use a drill, or similar tool, to avoid the perforation of the gas-filled compartment.

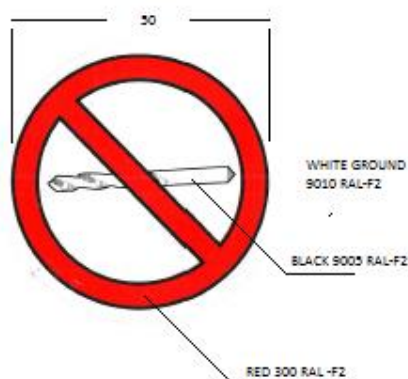

Figure 33 – Warning plate against drilling

7.3.18.4 Label holder

Every functional unit shall have a label holder with a transparent window with dimensions of 120x50 mm for indicating the feeder identification.



Figure 34 – Label Holder

Technical Specification code: GRI-GRI-MAT-E&C-0002

Version no.3 dated 03/10/2022

Subject: Enel Grids - GSM001 - Medium Voltage Gas Insulated Switchgears for secondary distribution substations**Application Areas**

Perimeter: Global

Staff Function: -

Service Function: -

Business Line: Enel Grids

7.3.18.5 Warning plate

Every functional unit shall have a warning plate on the access door to the cable compartment, clearly visible in-service condition, with the following characteristics:

- Triangle background: yellow.
- Arrow and triangle outline: black.
- Plate: Adhesive or attached to the door with rivets in stainless steel, aluminum, or 3 mm thick plastic.

For Colombia, this sign shall comply with the terms of article 6 of RETIE (Signal and Symbology).



Figure 35 – Warning Plate

7.3.19 Maintenance

The switchgear shall be maintenance free for the entire expected service life.

7.3.20 Packaging, handling and impact indicators (Shockwatch)

The switchgear enclosure shall have adequate strength, considering the stresses to which it is subject during transport. On the upper part of the switchgear, eye bolts shall be installed to allow movement by means of bridge crane, forklift, or overhead crane.

Technical Specification code: GRI-GRI-MAT-E&C-0002

Version no.3 dated 03/10/2022

Subject: Enel Grids - GSM001 - Medium Voltage Gas Insulated Switchgears for secondary distribution substations

Application Areas

Perimeter: Global

Staff Function: -

Service Function: -

Business Line: Enel Grids

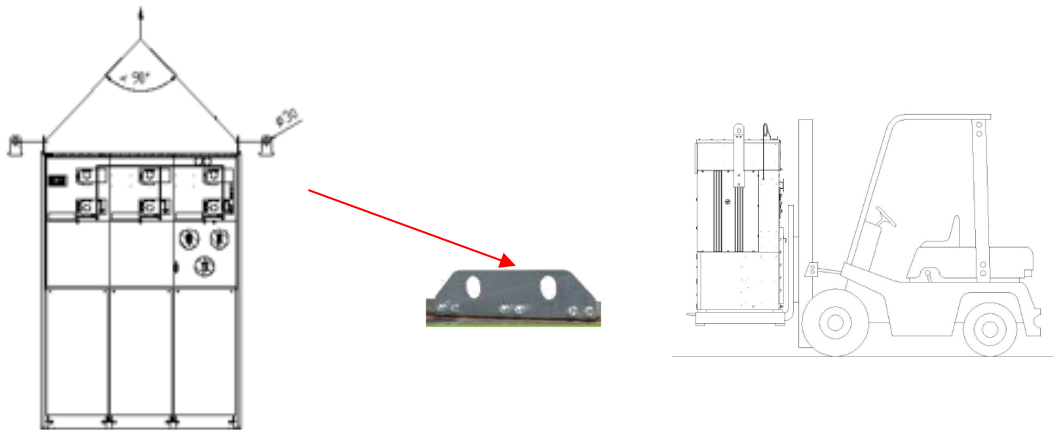

Figure 36 – Examples of handling

The switchgear shall be packed with a recyclable material waterproof film wrapped around it, with protective panels to shield the command part.

Each switchgear shall be equipped with a shock indicator (ShockWatch).

Indicators consist of labels containing a red liquid in suspension. If the device is subjected to an impact higher than a specific G level declared by the manufacturer, the impact will cause the red liquid to escape, clearly visible. The label shall be on the front of the appliance and clearly visible.



Figure 37 - ShockWatch

7.4 TESTING

Type test, routine test and factory acceptance tests shall be performed in compliance with the main IEC standards and the clarifications indicated in the following paragraphs. The tests described in the following paragraphs shall be carried out on the switchgear according to IEC 62271-102, IEC62271-103, IEC 62271-105, IEC 62271-200, and IEC 62271-100.

**Technical Specification code: GRI-GRI-MAT-E&C-0002**

Version no.3 dated 03/10/2022

Subject: Enel Grids - GSM001 - Medium Voltage Gas Insulated Switchgears for secondary distribution substations**Application Areas**

Perimeter: Global

Staff Function: -

Service Function: -

Business Line: Enel Grids

7.4.1 Type tests

Table 11 shows the list of type tests to be carried out on the switchgear.

For the validation of the modular functional units (prototype visual inspection included), the type tests shall be carried out, as minimum, on 2L+T switchgears, combined in such a way that all the following elements are tested:

- Line functional unit.
- Transformer protection functional unit.
- The connection kits.
- A final insulating cap installed on a line unit.
- A final insulating cap installed on a transformer unit.

All switching devices that are part of the switchgear shall pass all type tests foreseen in their respective standards: IEC 62271-102 and IEC 62271-103 for switch-disconnectors, IEC 62271-102 for earthing switches and IEC 62271-100 for circuit breaker (if any).

Technical Specification code: GRI-GRI-MAT-E&C-0002

Version no.3 dated 03/10/2022

Subject: Enel Grids - GSM001 - Medium Voltage Gas Insulated Switchgears for secondary distribution substations

Application Areas

Perimeter: Global

Staff Function: -

Service Function: -

Business Line: Enel Grids

TEST	STANDARD	CHAPTER
Switchgear and controlgear		
Visual inspection	GSM001	
Dielectric tests	IEC 62271-200	7.2
Radio interference voltage (RIV) test	IEC 62271-200	7.3
Measurement of the resistance of the main circuit and auxiliary circuits	IEC 62271-200	7.4
Continuous current test	IEC 62271-200	7.5
Short-time withstand current and peak withstand current tests	IEC 62271-200	7.6
Verification of the protection (IP and IK)	IEC 62271-200	7.7
Tightness tests	IEC 62271-200	7.8
Electromagnetic compatibility tests (EMC)	IEC 62271-200	7.9
Additional test on auxiliary and control circuits	IEC 62271-200	7.10
X-radiation test for vacuum interrupters	IEC 62271-102	7.11
Verification of making and breaking capacities	IEC 62271-200	7.101
Mechanical operation tests	IEC 62271-200	7.102
Pressure withstand test for gas-filled compartments	IEC 62271-200	7.103
Internal arc test	IEC 62271-200	7.105
Check painting requirements (C3-HIGH or C5-HIGH)	ISO 12944-6	ISO 12944-6
Verification of the protective coating	ISO 2409	LEVEL 0 (applicable to all switchgears material codes)
Environmental testing	IEC 60068-2-52	METHOD 5 (only applicable for "basic protection" switchgear)
Environmental testing	IEC 60068-2-52	METHOD 6 (only applicable for "high protection" switchgear)
Seismic test	IEC TS 62271-210	Severity level 1 – PGA 0,5 g– CLASS 2
Switch-disconnector (SD)		
Dielectric tests	IEC 62271-102	7.2
Radio interference voltage (RIV) test	IEC 62271-102	7.3
Measurement of the resistance of the main circuit and auxiliary circuits	IEC 62271-102	7.4
Continuous current test	IEC 62271-102	7.5
Short-time withstand current and peak withstand current tests	IEC 62271-102	7.6
Verification of the protection (IP and IK)	IEC 62271-102	7.7
Tightness tests	IEC 62271-102	7.8
Electromagnetic compatibility tests (EMC)	IEC 62271-102	7.9
Additional test on auxiliary and control circuits	IEC 62271-102	7.10

Technical Specification code: GRI-GRI-MAT-E&C-0002

Version no.3 dated 03/10/2022

Subject: Enel Grids - GSM001 - Medium Voltage Gas Insulated Switchgears for secondary distribution substations

Application Areas

Perimeter: Global

Staff Function: -

Service Function: -

Business Line: Enel Grids

X-radiation test for vacuum interrupters	IEC 62271-102	7.11
Verification of making and breaking capacities	IEC 62271-102	7.101
Operating and mechanical endurance tests	IEC 62271-102	7.102
Low-and high temperature tests	IEC 62271-102	7.104
Tests to verify the proper functioning of the position indicating device	IEC 62271-102	7.105
Earthing switches (ES)		
Dielectric tests	IEC 62271-103	7.2
Radio interference voltage (RIV) test	IEC 62271-103	7.3
Resistance measurement	IEC 62271-103	7.4
Continuous current test	IEC 62271-103	7.5
Short-time withstand current and peak withstand current tests	IEC 62271-103	7.6
Verification of the protection (IP and IK)	IEC 62271-103	7.7
Tightness tests	IEC 62271-103	7.8
Electromagnetic compatibility tests (EMC)	IEC 62271-103	7.9
Additional test on auxiliary and control circuits	IEC 62271-103	7.10
X-radiation test for vacuum interrupters	IEC 62271-102	7.11
Making and breaking tests	IEC 62271-103	7.101
Switch-disconnector combined with fuses		
Dielectric tests	IEC 62271-105	7.2
Radio interference voltage (RIV) test	IEC 62271-105	7.3
Measurement of the resistance of the main circuit and auxiliary circuits	IEC 62271-105	7.4
Continuous current test	IEC 62271-105	7.5
Short-time withstand current and peak withstand current tests	IEC 62271-105	7.6
Verification of the protection (IP and IK)	IEC 62271-105	7.7
Tightness tests	IEC 62271-105	7.8
Electromagnetic compatibility tests (EMC)	IEC 62271-105	7.9
Additional test on auxiliary and control circuits	IEC 62271-105	7.10
X-radiation test for vacuum interrupters	IEC 62271-102	7.11
Verification of making and breaking capacities	IEC 62271-105	7.101
Mechanical operation test	IEC 62271-105	7.102
Mechanical shock test on fuses	IEC 62271-105	7.103
Thermal test with long pre-arcing time of fuse	IEC 62271-105	7.104

Technical Specification code: GRI-GRI-MAT-E&C-0002

Version no.3 dated 03/10/2022

Subject: Enel Grids - GSM001 - Medium Voltage Gas Insulated Switchgears for secondary distribution substations

Application Areas

Perimeter: Global

Staff Function: -

Service Function: -

Business Line: Enel Grids

Circuit breaker		
See type tests referred to in GSCM004		
LPVT		
TEST	IEC 61869 TABLE 10 - GSCT005 INTEGRATION TEST	
SOCKET		
TEST	IEC 61243-5	TABLE A.3
VDIS		
TEST	IEC 62271-213	TABLE 4

Table 11 – List of Type Test on the switchgear
7.4.1.1 Internal arc test

For the internal arc test on the cable trench, gas expansion towards the cable trench is permissible. The verification of the internal arc test in the cable compartment shall be carried according to the following instructions:

- The gas pressure generated will have to be dispersed in the cable shaft.
- If the pressure valve is triggered, the gas will have to vent into the trench behind the cable compartment.

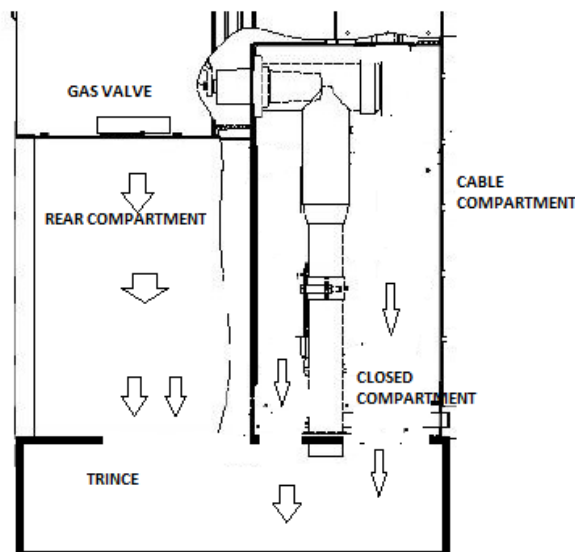
Figure 38 – Gas pressure release

**Technical Specification code: GRI-GRI-MAT-E&C-0002**

Version no.3 dated 03/10/2022

Subject: Enel Grids - GSM001 - Medium Voltage Gas Insulated Switchgears for secondary distribution substations**Application Areas**

Perimeter: Global

Staff Function: -

Service Function: -

Business Line: Enel Grids

7.4.1.2 Temperature-rise tests for switch-fuse combinations

The temperature-rise tests of the switch-fuse combination shall be carried out as follows:

- For 24 kV switchgear:
 - The test shall be carried out using a set of fuses with a rated current ≥ 100 A
 - During the test, the power dissipation in the fuse-link will be ≥ 90 W
 - The minimum current through the fuses shall be 50 A
- For 36 kV switchgear:
 - The test shall be carried out using a set of fuses with a rated current ≥ 63 A
 - During the test, the power dissipation in the fuse-link will be ≥ 90 W.
 - The minimum current through the fuses shall be 30 A

With these conditions, chapter 7.105.2 of IEC 62271-105 applies.

7.4.2 Routine tests

Table 12 shows the list of routine tests to be carried out on the switchgear, LPVT and VDS.

Routine tests shall be carried out at the factory by the manufacturer on all equipment to ensure that the equipment corresponds to the type-tested equipment.

Technical Specification code: GRI-GRI-MAT-E&C-0002

Version no.3 dated 03/10/2022

Subject: Enel Grids - GSM001 - Medium Voltage Gas Insulated Switchgears for secondary distribution substations

Application Areas

Perimeter: Global

Staff Function: -

Service Function: -

Business Line: Enel Grids

TEST	STANDARD
Switchgear and controlgear	
Dielectric test on the main circuit	IEC 62271-200-102-103-105
Tests on auxiliary and control circuits	IEC 62271-200-102-103-105
Measurement of the resistance of the main circuit	IEC 62271-200-102-103-105
Tightness tests	IEC 62271-200-102-103-105
Design and visual checks	IEC 62271-200-102-103-105
Partial discharge measurement	IEC 62271-200-102-103-105
Mechanical operation tests	IEC 62271-200-102-103-105
Pressure tests of gas-filled compartments	IEC 62271-200
Tests of auxiliary electrical, pneumatic, and hydraulic devices	IEC 62271-200
Measurement of fluid condition after filling on site	IEC 62271-200
Verification of earthing function	IEC 62271-102
LPVT	
Power-frequency voltage withstand tests on primary terminals	IEC 61869-11 TABLE11
Partial discharge measurement	IEC 61869-11 TABLE11
Test for accuracy	IEC 61869-11 TABLE11
Verification of markings	IEC 61869-11 TABLE11
Enclosure tightness test at ambient temperature	IEC 61869-11 TABLE11
Pressure test for the enclosure	IEC 61869-11 TABLE11
Measurement of capacitance and dissipation factor at power frequency	IEC 61869-11 TABLE11 AND GSCT005
CIRCUIT BREAKER	
See type tests referred to in GSCM004	
VDIS	
Arrangement, assembly, markings, instructions for use	IEC 62271-213 TABLE 6
Conditions on testing points	IEC 62271-213 TABLE 6
Indication	IEC 62271-213 TABLE 6
SOCKET	
Arrangement assembly, markings, instruction for use	EN 61243-5 TABLE A.3
Clear indication	EN 61243-5 TABLE A.3

Table 12 - List of routine tests for MV switchgear
7.4.3 Factory acceptance tests

All the tests indicated Table 14 shall be carried out by the supplier on all the samples prepared for the commissioning. For each piece that belongs to the prepared batch, the supplier shall prepare a test report with the results of the tests performed.

Technical Specification code: GRI-GRI-MAT-E&C-0002

Version no.3 dated 03/10/2022

Subject: Enel Grids - GSM001 - Medium Voltage Gas Insulated Switchgears for secondary distribution substations

Application Areas

Perimeter: Global

Staff Function: -

Service Function: -

Business Line: Enel Grids

The acceptance tests shall be repeated by the supplier, under the Distribution Companies surveillance, on a sample chosen randomly among those ones of the batch that has already been successfully tested by the supplier. The tests shall be carried out on samples defined by the sampling plan below:

A	1 sample for type
B	Sampling plan: Single sampling plan for normal inspection - AQL = 2,5% - Level II (in case of negative result, in the new commissioning the sampling plan shall be ordinary)
C	Documental check of the test reports provided by the supplier regarding the tests performed autonomously on the batch

Lot size	Sample	Ac	Re
0-5	100%	0	1
6-150	5	0	1
151-500	20	1	2
501-1200	32	2	3
1201-3200	50	3	4
3201-10000	80	5	6

Table 13 – Sampling Plan Application of sampling plan type B

Technical Specification code: GRI-GRI-MAT-E&C-0002

Version no.3 dated 03/10/2022

Subject: Enel Grids - GSM001 - Medium Voltage Gas Insulated Switchgears for secondary distribution substations

Application Areas

Perimeter: Global

Staff Function: -

Service Function: -

Business Line: Enel Grids

Test	Standard		Sampling plan		
			Transf. Unit	Line Unit	RMU multi Unit (m)
Visual inspection (a)			A	A	A
Dielectric test on the main circuit (f) (l)	IEC 62271-200-102-103-105	8.2	B	B	B
Tests on auxiliary and control circuits (b)	IEC 62271-200-102-103-105 § 8.3	8.3	B	B	B
Measurement of the resistance of the main circuit (e)	IEC 62271-200-102-103-105	8.4	B	B	B
Tightness test (D)	IEC 62271-200-102-103-105	8.5	C	C	C
Design and visual checks (a) (l)	IEC 62271-200-102-103-105	8.6	A	A	A
Partial discharge measurement (i)	IEC 62271-200-102-103-105	8.101	C	C	C
Mechanical operating tests (c)	IEC 62271-102 -105	8.101	B	B	B
Mechanical operation tests (c)	IEC 62271-200-103	8.102	B	B	B
Verification of earthing function	IEC 62271-102	8.102	B	B	B
Verification of proactive coating (g)	ISO 2808		B	B	B
Indication of VDIS and SOCKET (m)	IEC 62271-213 / IEC 61243-5	7.7 / 5.11	B	B	B
Dry-film thickness	ISO 2808		B	B	B
Verification of the protective coating	ISO 2409	LEVEL 0	A	A	A
Control of the degree of protection (IP51)			C	C	C
Assembly check (i)	IEC 62271-200	6.7	B	B	NA
Circuit breaker	See type tests referred to in GSCM004				

Table 14 – Factory Acceptance test list and sampling

Technical Specification code: GRI-GRI-MAT-E&C-0002

Version no.3 dated 03/10/2022

Subject: Enel Grids - GSM001 - Medium Voltage Gas Insulated Switchgears for secondary distribution substations

Application Areas

Perimeter: Global

Staff Function: -

Service Function: -

Business Line: Enel Grids

a	Including the verification of the gas –filled compartment s' degree of protection (IP), and in case of modular equipment the verification of the pairings.
b	1 kV power frequency testing voltage (10 kV for trip coil) during 1 second.
c	perform 5 manual maneuvers of the SD (transformer) measuring the speed of the main contacts in opening and closing and 5 manual operations of the earthing switch Es (line) and of the earthing switches ES1 - ES2 (transformer) measuring the speed of the pristip contacts in closure. During the maneuvers verify all the mechanical interlocks provided. The test also includes verification of correct fuse installation and extraction using a real fuse or a test fuse as defined during the approval process (TCA).
d	5 closing and 5 opening operations at V_{min} (24 Vcc-15%) and V_{max} (24 Vcc + 20%). At V_n (24 Vcc) perform 5 C-O cycles and 5 Ot-C-O cycles. In the last cycle of every sequence, measure the operation times, the absorption current of the coils and of the spring charging motor. All the measured times and maximum values of absorption shall be included in the limits specified by the Manufacturer and, in any case, they shan't be outside the $\pm 15\%$ of the reference values obtained during the type tests.
e	Test to be performed on the same configuration used during the homologation process.
g	The test shall be performed with the operating devices closed and on the sectioning distance. All the tests shall be performed at a 50 kV power frequency voltage (for 24 kV switch-disconnector) or 70 kV power frequency voltage (for 36 kV switch-disconnector).
h	Perform the thickness verification with sampling plan "B" and the adherence verification on one sample only.
i	Test to be certified on single units by the supplier
l	Line and Transformer modules shall be tested in connection with each other
m	The test will be performed during the dielectric test

Table 15 – Additional information regarding FAT

7.5 SUPPLY REQUIREMENTS

Each switchgear described here in shall be supplied ensuring a proper protection during the transportation and storage. For each equipment, the manufactured shall supply:

- In case of modular switchgears, the plug-in unit (contact coupling and screened insulated caps).
- The command levers required to operate the switchgear.
- Manuals (switchgears, VDIS/VDS, LPIT, etc.) in compliance with the reference standard.
- A connection cable to connect the transformer protection functional unit with the RTU.
- Per Edesur:
 - For each Line Functional unit separable connectors 3 separable connectors. For 36 kV GSCC006/51 or for 24 kV GSCC006/29;
 - For each transformers protection functional unit 3 separable connectors. For 36 kV GSCC006/18 or for 24 kV GSCC006/12.
- Declaración de Conformidad according to RD337/2014 (Only for **Spain**).
- RETIE (Only for **Colombia**)

**Technical Specification code: GRI-GRI-MAT-E&C-0002**

Version no.3 dated 03/10/2022

Subject: Enel Grids - GSM001 - Medium Voltage Gas Insulated Switchgears for secondary distribution substations

Application Areas

Perimeter: Global

Staff Function: -

Service Function: -

Business Line: Enel Grids

Outside the box containing the equipment, the following indications shall be reported with clearly legible characters:

- Distribution system operator (DSO) Company name
- Supplier Name.
- description of the product.
- Supplier product designation
- Enel material code and type code
- gross weight.
- Barcode according to CNS-O&M-S&L-2021-0032-EGIN.

The compact switchgear 5L+1T shall be supplied in the following composition 3L and 2L+1T.

The equipment shall be supplied unpacked on two platforms and assembly shall take place on site.

The equipment shall be fitted with extension terminations on the sides of the units to allow for coupling.

Technical Specification code: GRI-GRI-MAT-E&C-0002

Version no.3 dated 03/10/2022

Subject: Enel Grids - GSM001 - Medium Voltage Gas Insulated Switchgears for secondary distribution substations

Application Areas

Perimeter: Global

Staff Function: -

Service Function: -

Business Line: Enel Grids

7.6 INTERLOCKS CHECKING

To verify the correct functioning of the interlocks, it is necessary to check their operation according to the tables below:

Status	Switch-disconnector	Earthing switches	Allowed	Forbidden	Impossible	Possible access to fuse and cable compartment
0	OPEN	OPEN	0,1,2	-	3	NO
1	OPEN	CLOSED	0,1	3	2	YES
2	CLOSED	OPEN	0,2	3	1	NO
3	CLOSED	CLOSED	-	-	-	-

Table 16 – Transformer Protection functional unit interlocks.

Status	Switch-disconnector	Earthing switch	Allowed	Forbidden (Both manual operation and motorized operation)	Impossible	Possible access to fuse and cable compartment
0	OPEN	OPEN	0,1,2		3	NO
1	OPEN	CLOSED	0,1	3	2	YES
2	CLOSED	OPEN	0,2	3	1	NO
3	CLOSED	CLOSED	-	-	-	-

Table 17 – Line functional unit interlocks.

 Non reachable status

While the access door to the cable compartment or the access panel to the fuses is removed, for the transformer Protection functional unit, it shall be considered:

- A mechanical interlock that prevents the manual operation of the switch disconnector.
- An electrical interlock that prevents the motorized operation of the switch disconnector (both by pushbutton and remotely).
- A mechanical interlock that prevents the operation of the earthing switch.

While the access door to the cable compartment is removed (Line functional unit), it shall be considered:

- The earthing switch could be opened after the insertion of screwdriver, but only one time (for Cable testing purposes).
- The interlock for open the earthing switch returns when the screwdriver is removed. The earthing switch can be closed, but it cannot be opened once again without the use of the screwdriver.

Technical Specification code: GRI-GRI-MAT-E&C-0002

Version no.3 dated 03/10/2022

Subject: Enel Grids - GSM001 - Medium Voltage Gas Insulated Switchgears for secondary distribution substations

Application Areas

Perimeter: Global

Staff Function: -

Service Function: -

Business Line: Enel Grids

- The switch-disconnector remains locked in any case, regardless the position of the earthing switch.
- The access door cannot be replaced if the earthing switch is open.

The insertion of the command lever in both operation points (switch-disconnector and earthing switch) prevents the motorized operation of the switch-disconnector.

7.7 CHARACTERISTICS OF THE ELECTRICAL COMMAND

7.7.1 Electric motor

The switch-disconnector will be operated by an electric motor, suitable for continuous service, having the following characteristics:

Supply voltage	[V _{cc}]	24 +20% -15%
Power consumption at full speed	[W]	≤ 300
Degree of protection		≥ IP3X

Table 18 – Electric Motor characteristics

7.7.2 Electric command of the switch-disconnector

The kinematic mechanism of the line disconnector shall not be energy storage.

Functional characteristics:

- component shall have stable positions with spring charged.
- the stability of the switch-disconnector contact position shall be guaranteed until the spring has accumulated enough energy to operate.
- if a power failure occurs during any operation, before the spring will have accumulated energy, the system shall allow the kinematic mechanism to be reset so that the control lever can be engaged.
- the motorization circuit shall not absorb any current when it is in the stand-by state.
- if the motor circuit has no supply voltage, no command shall be memorized.

An electrical interlock shall allow the motorized operation only when the earthing blades are fully open. In case of manual command, the insertion of the lever shall prevent the motorized operation; such interlock shall already act before the end of the lever engages on the tang of whatever operating shafts.

**Technical Specification code: GRI-GRI-MAT-E&C-0002**

Version no.3 dated 03/10/2022

Subject: Enel Grids - GSM001 - Medium Voltage Gas Insulated Switchgears for secondary distribution substations**Application Areas**

Perimeter: Global

Staff Function: -

Service Function: -

Business Line: Enel Grids

This condition can be realized with both a mechanical (decoupling the gear motor) and electric solution (cutting the power of the motor).

The input impedance of the command circuit shall be in the range of 5-5000 Ω .

7.7.3 Connections

The energy for the motorized control is supplied by the remote terminal unit (RTU) power supply.

The supply circuits for the motors ($\pm M$) and for the auxiliaries ($\pm A$) shall remain separate and isolated from each other and are protected by different bipolar protections in the power supply.

7.7.4 Connectors

To interface the electrical control circuit with the external RTU, it is necessary to provide the fixed part of a circular connector, onto which the detachable connector of the type shall be inserted. (See Figure 39).

The coupling of the parts shall be ensured by means of a quick-release screw ring nut.

Technical Specification code: GRI-GRI-MAT-E&C-0002

Version no.3 dated 03/10/2022

Subject: Enel Grids - GSM001 - Medium Voltage Gas Insulated Switchgears for secondary distribution substations

Application Areas

Perimeter: Global

Staff Function: -

Service Function: -

Business Line: Enel Grids

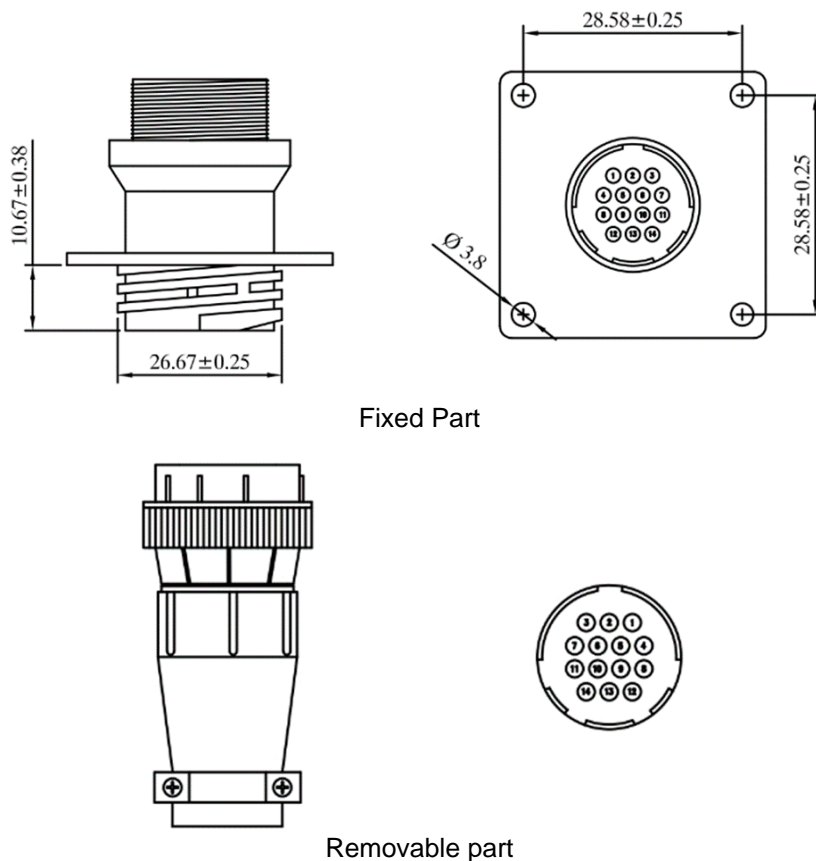
Figure 39 – Connector at switchgear side

The fixed part shall be made of insulating material with dielectric characteristics.

The fixed part of the connector shall be accompanied by a cap (anti loss type); the removable one shall have cable clamps.

The position of the connector shall be placed on the corresponding of the line functional unit and once the removable part is connected, the cable shall not interfere with any of the switching or signaling elements of the control equipment.

The cable shall not be supplied.

Subject: Enel Grids - GSM001 - Medium Voltage Gas Insulated Switchgears for secondary distribution substations

Application Areas

Perimeter: Global

Staff Function: -

Service Function: -

Business Line: Enel Grids

7.7.5 Wiring

For internal wiring shall be used wire sections suitable for the correct operation of the equipment.

The end of each connection shall be equipped with pre-insulated terminals suitable for the type of connection required (fasten, cylindrical, eyelet, etc.), identification marks, as well as reference to the wiring diagram.

Each cable passage hole shall be equipped with a suitable cable gland.

The wiring diagram of the cables should be as follows:

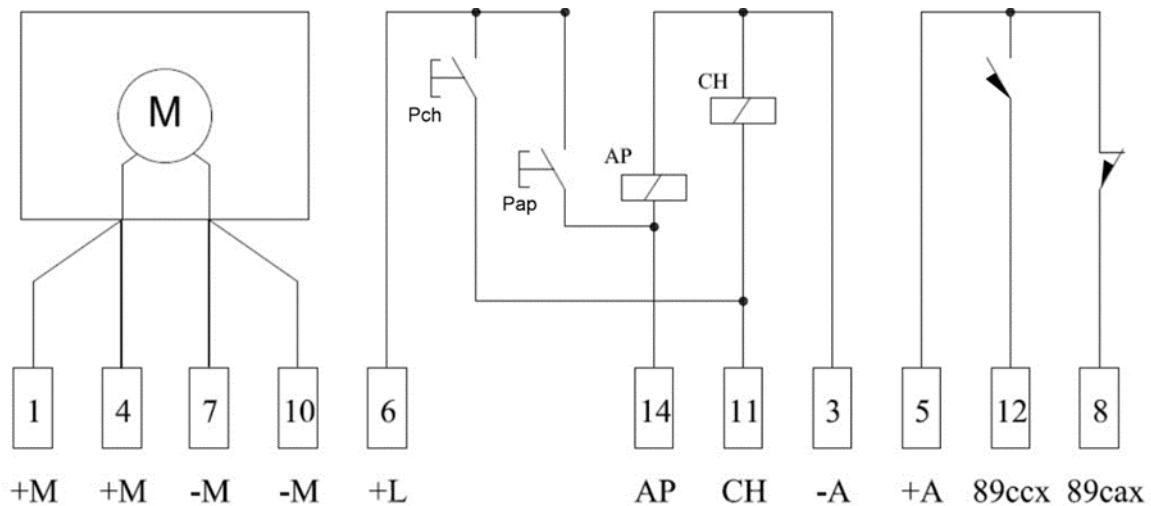

Figure 40 – Electric scheme of switch-disconnector command

Technical Specification code: GRI-GRI-MAT-E&C-0002

Version no.3 dated 03/10/2022

Subject: Enel Grids - GSM001 - Medium Voltage Gas Insulated Switchgears for secondary distribution substations

Application Areas

Perimeter: Global

Staff Function: -

Service Function: -

Business Line: Enel Grids

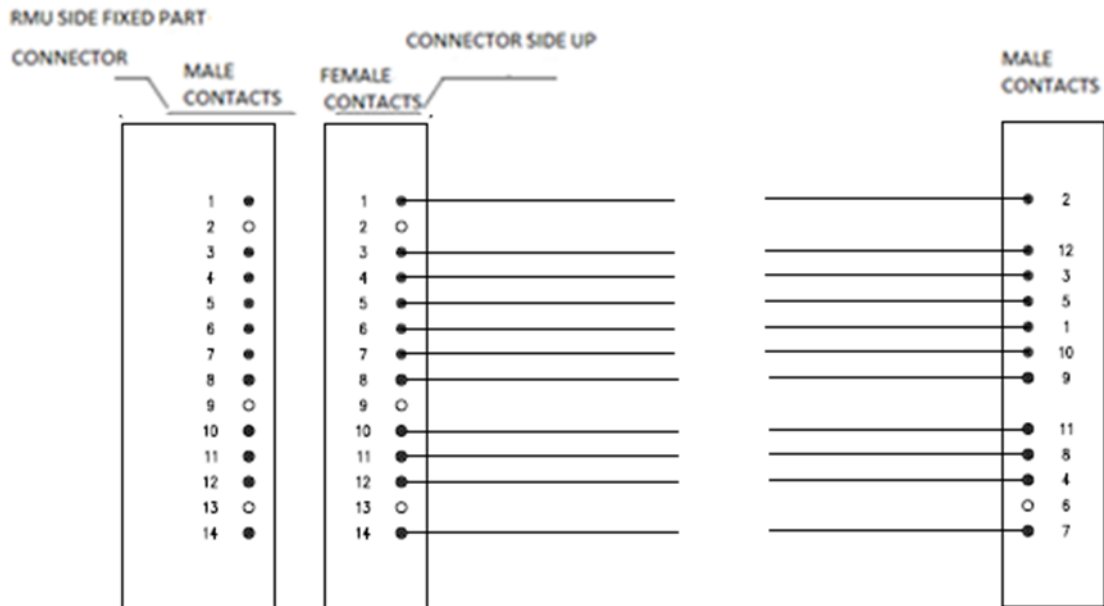
Figure 41 – Pin connection scheme for switch-disconnector command

1	+M	Motor supply voltage (+24 Vcc)	8	89cax	Signal opening position switch-disconnector
2		Not used	9		Not used
3	- A	Common (-24 Vcc) commands	10	- M	Motor supply voltage (-24 Vcc)
4	+ M	Motor supply voltage (+24 Vcc)	11	CH	Closing command
5	Com TS	Common position signals switch-disconnector	12	89ccx	Signal closing position switch-disconnector
6	+ L	Local commands supply (+24 Vcc)	13		Not used
7	- M	Power supply (-24 VDC) motor	14	AP	Opening command

Table 19 – Pin definition on motor side

Technical Specification code: GRI-GRI-MAT-E&C-0002

Version no.3 dated 03/10/2022

Subject: Enel Grids - GSM001 - Medium Voltage Gas Insulated Switchgears for secondary distribution substations

Application Areas

Perimeter: Global

Staff Function: -

Service Function: -

Business Line: Enel Grids

1	+ L	Local commands supply (+24 Vcc)	7	AP	Opening command
2	+ M	Motor supply voltage (+24 Vcc)	8	CH	Closing command
3	+ M	Motor supply voltage (+24 Vcc)	9	89cax	Signal opening position switch-disconnector
4	89ccx	Signal closing position switch-disconnector	10	- M	Power supply (-24 VDC) motor
5	Com TS	Common position signals switch-disconnector	11	- M	Power supply (-24 VDC) motor
6		Not used	12	- A	Common (-24 Vcc) commands

Table 20 – Pin definition RTU side (For information purposes)



Technical Specification code: GRI-GRI-MAT-E&C-0002

Version no.3 dated 03/10/2022

Subject: Enel Grids - GSM001 - Medium Voltage Gas Insulated Switchgears for secondary distribution substations

Application Areas

Perimeter: Global

Staff Function: -

Service Function: -

Business Line: Enel Grids

7.8 MV RMU “AUX” UNIT

The purpose of this annex is to define an alternative functional scheme specifically, for switchgears with a functionality that allows supplying 230V power to the auxiliary services of Secondary Substations, both to the lighting circuit and to the remote-control circuit.

This functionality shall be able to be integrated into a compact ring main unit (RMU) described here in this document or supplied in a modular format for field bonding, integrating the desired final configuration with other modular functionalities herein described.

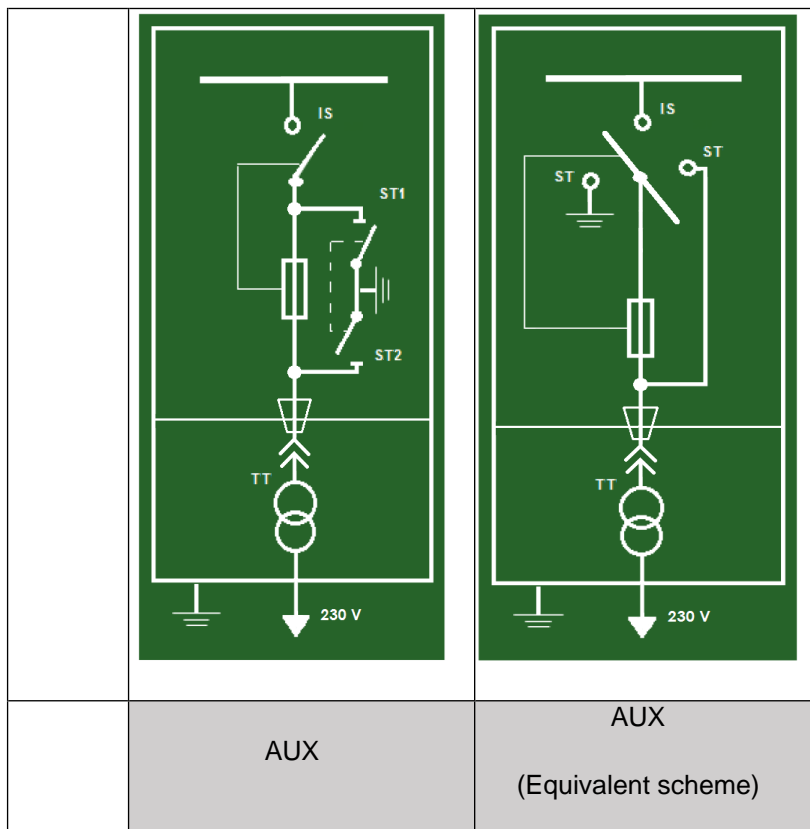

Figure 42 - “AUX” unit electrical scheme

Technical Specification code: GRI-GRI-MAT-E&C-0002

Version no.3 dated 03/10/2022

Subject: Enel Grids - GSM001 - Medium Voltage Gas Insulated Switchgears for secondary distribution substations

Application Areas

Perimeter: Global

Staff Function: -

Service Function: -

Business Line: Enel Grids

7.8.1 Application field

The power supply unit for auxiliary services "AUX" is intended to be installed in those MV Switching Substation or Delivery Substation to MV customers in which there is no MV/LV transformation owned by Enel Companies.

7.8.2 General Characteristic

The "AUX" unit will be implemented by a Transformer Protection Unit, already defined in the Enel standard GSM001 Rev.3 as type "T", to which a voltage transformer is incorporated in the cable compartment, by a damping resistor for ferroresonance phenomena and by protection and connection modules for the power supply of auxiliary services in the secondary substation.

Below is an example of a constructive solution with all the indicated elements:

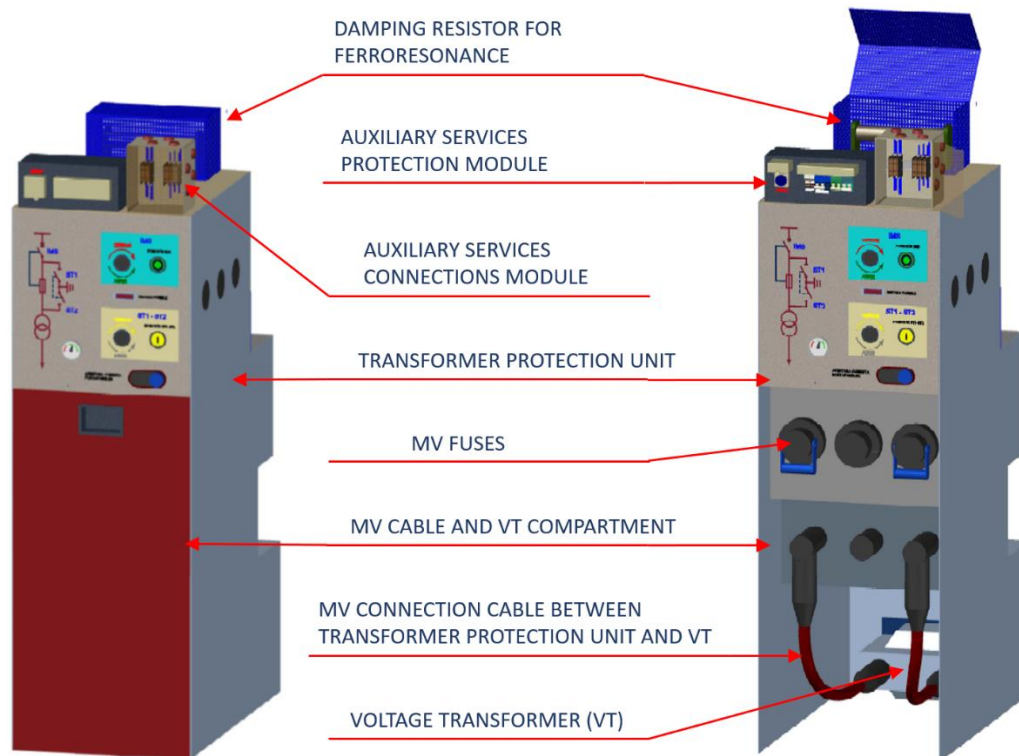

Figure 43 - Example of general configuration of an "AUX" type unit

Subject: Enel Grids - GSM001 - Medium Voltage Gas Insulated Switchgears for secondary distribution substations

Application Areas

Perimeter: Global

Staff Function: -

Service Function: -

Business Line: Enel Grids

7.8.3 Transformer protection unit.

The functionality of the “AUX” unit will be implemented by a Transformer Protection Unit which, except for the points expressly indicated in this annex, shall comply with the requirements of § 7.3.5, both in the design and construction requirements and in the test requirements. In this Transformer Protection Unit will be incorporated a voltage transformer, in the MV cable compartment, protection and connection modules for the substation auxiliary circuits connection and a damping resistor for ferroresonance phenomena.

To optimize the space available for the voltage transformer in the MV cable compartment, it will be allowed that the maximum depth of the Ur=36kV units may increase by 80mm with respect to what is specified in §7.3.14, extending towards the rear without negatively affecting the internal arc characteristics of the switchgear:

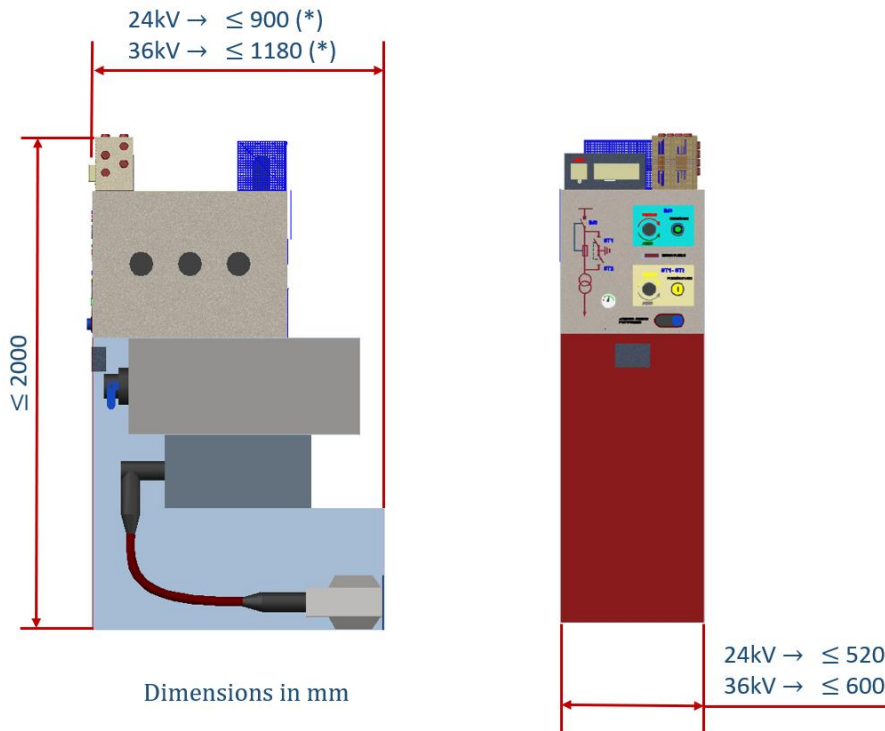

(*) Maximum depth including the space required between the switchgear and the rear wall (In those parts of the switchgear where separation from the rear wall is not required, these maximum depths may be of physical occupation).

Figure 44 - maximum dimensions of an “AUX” type unit

Technical Specification code: GRI-GRI-MAT-E&C-0002

Version no.3 dated 03/10/2022

Subject: Enel Grids - GSM001 - Medium Voltage Gas Insulated Switchgears for secondary distribution substations

Application Areas

Perimeter: Global

Staff Function: -

Service Function: -

Business Line: Enel Grids

The “AUX” unit will be supplied with MV fuses inserted in the side phases (L1-L3) feeding the voltage transformer, while in the central phase (L2) the fuse-holder tube will be empty and with the access cover mechanically blocked so that there is no possibility of opening during the operation of the switchgear.

The central connection of the MV output of the unit, in the cable compartment, will be supplied protected with an insulating cap, compatible with the existing bushings standardized according to EN50181, which must remain firmly installed during operation. This cap will have an external equipotential surface that must be connected to the switchgear grounding.

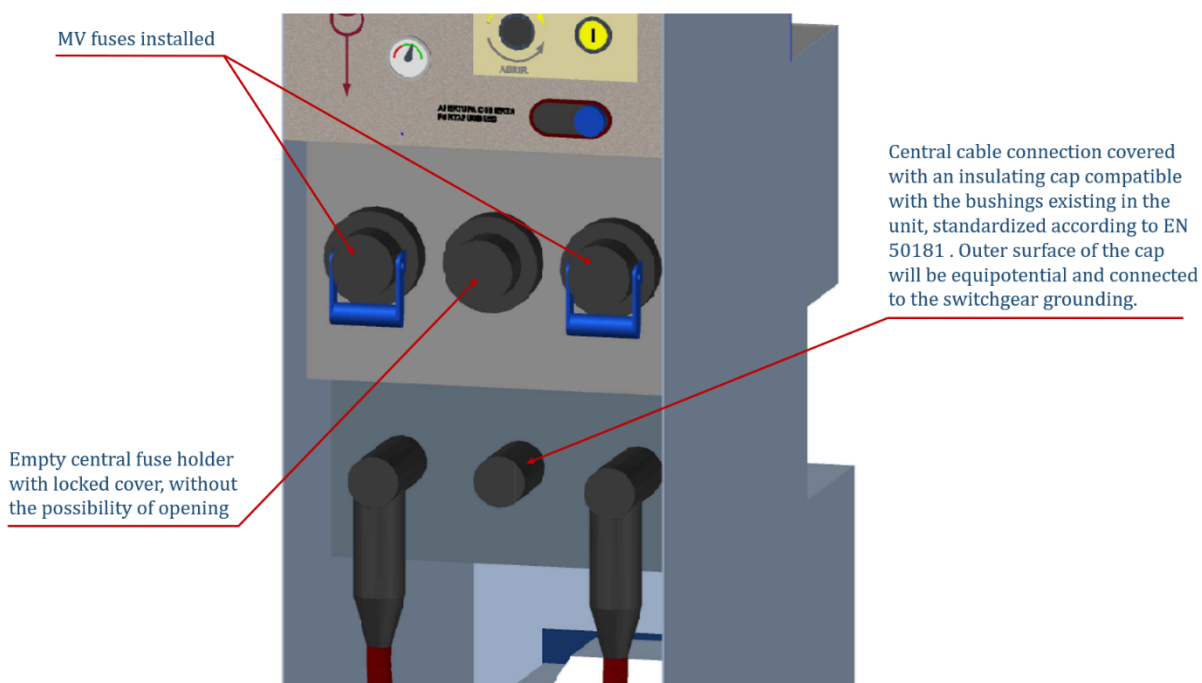

Figure 45 - Fuses installed on side phases and central fuse holder empty and blocked.

In the side phases, current limiting back-up fuses, according to the standard EN 60282-1 and GSM001 shall be provided.

The fuses installed shall be approved by Enel. They will have the same rated voltage as the switchgear in which they are installed and will have a rated current of 6.3A in the case of $U_r=24\text{kV}$ and a rated current of 5A in the case of $U_r=36\text{kV}$. Its rated maximum breaking current (I_1) will be greater than or equal to 20kA.

Technical Specification code: GRI-GRI-MAT-E&C-0002

Version no.3 dated 03/10/2022

Subject: Enel Grids - GSM001 - Medium Voltage Gas Insulated Switchgears for secondary distribution substations

Application Areas

Perimeter: Global

Staff Function: -

Service Function: -

Business Line: Enel Grids

The cable compartment enclosure, together with the protection implemented by means of the fuses, must be able to prevent projections of material in the event of an internal fault in the voltage transformer that it houses, maintaining the internal arc classification also in this case. To guarantee this requirement, the switchgear must successfully pass the additional test indicated above.

7.8.4 Voltage transformer (VT)

In the cable compartment of the "AUX" unit, a voltage transformer will be installed in accordance with the EN 61869-1 and EN 61869-3 standards, to provide a 230V for powering the auxiliary services of the secondary substation in which the switchgear is installed. The voltage transformers intended to be connected alternately to different mains voltages in their primary, must have the corresponding secondary connections (double tap secondary winding) so that the 230V necessary to supply the auxiliary services can be offered in any case.

The primary of the voltage transformer shall be phase-phase type and shall incorporate external cone plug-in bushings in accordance with the EN 50181 standard. It shall be connected to the side phases at the MV output of the "transformer protection unit" by means of an insulated and screened jumper, made up with cable according to Enel standard GSC001 and plugin connectors according to Enel standard GSC006. The jumper screen shall be connected to the switchgear grounding. For technical and duly justified reasons, the manufacturer may propose different solutions to the one indicated here to implement the interconnection jumper between switchgear and voltage transformer but, in any case, they must be explicitly approved by Enel.

The voltage transformer must be easily replaceable from the switchgear front once the cable compartment door has been removed.

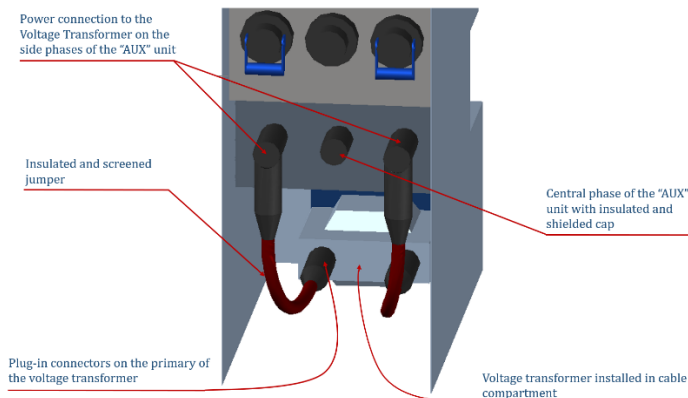

Figure 46 - Detail of the cable compartment of the "AUX" unit with the Voltage Transformer installed

The voltage transformers installed in the "AUX" units will have the following common characteristics:

Technical Specification code: GRI-GRI-MAT-E&C-0002

Version no.3 dated 03/10/2022

Subject: Enel Grids - GSM001 - Medium Voltage Gas Insulated Switchgears for secondary distribution substations

Application Areas

Perimeter: Global

Staff Function: -

Service Function: -

Business Line: Enel Grids

- Rated secondary voltage: 230V.
- Rated frequency: 50Hz
- Accuracy power: $\geq 200\text{VA}$
- Rated accuracy class: Class 3.
- Thermal Power: $\geq 500\text{VA}$
- Induction ≤ 1 Tesla.
- Rated voltage factor ≥ 1.9 (30 seconds) / 1.2 Continuous.
- Service conditions: Indoor, according EN 61869-1 and EN 61869-3.
- Ambient air temperature: -5°C / 40°C .
- Altitude: $\leq 1500\text{m}$.
- Includes overpressure release valve.

In addition, Table 21 indicates the specific characteristics that the voltage transformers shall have depending on the network voltages to which the primary shall be connected.

	Switchgear Ur=24kV		Switchgear Ur=36kV	
Mains voltages for primary connection (V)	10000/15000	15000/20000	11000	25000
Highest voltage for equipment, Um (kV)	17,5 ^(*)	24	17,5 ^(**)	36
Rated power-frequency withstand voltage (kV)	38	50	38	70
Rated lightning impulse withstand voltage (kV)	95	125	95	170
External cone bushing type in primary connections, according to EN50181	Type A, B o C	Type A, B o C	Type B o C ^(***)	Type B o C ^(***)
Número de tomas en el secundario	2	2	1	1

Subject: Enel Grids - GSM001 - Medium Voltage Gas Insulated Switchgears for secondary distribution substations

Application Areas

Perimeter: Global

Staff Function: -

Service Function: -

Business Line: Enel Grids

(*) The interconnection jumper between swinger and VT will have a rated voltage $U_0/U(U_m) = 12/20(24)$ kV (both in cables and in connectors).

(**) The interconnection jumper between swinger and VT will have a rated voltage $U_0/U(U_m) = 18/30$ (36) kV (both in cables and in connectors).

(***) The "AUX" units with $U_r=36$ kV and belonging to the same family, incorporate the same type of bushings for both 11kV network voltages and 25kV network voltages

Table 21 - Specific characteristics of the VT depending on the mains voltages for primary connection

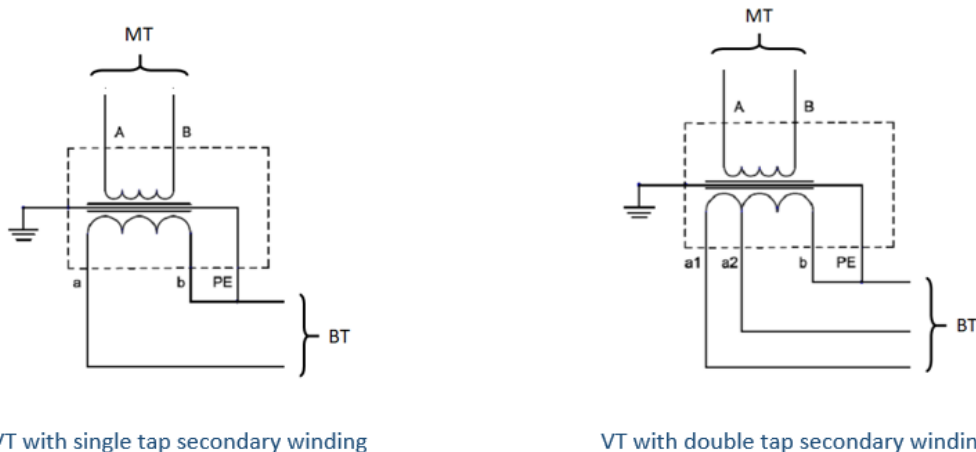

VT with single tap secondary winding

VT with double tap secondary winding

Figure 47 - Electrical diagram of VTs with single and double tap secondary winding

It should be foreseen that in AUX units with $U_r=36$ kV that incorporates a 11kV primary voltage VT it will be possible to replace it in the field with a 25kV primary voltage VT, with no further operations than reconnection, in the switchgear cable compartment, of the primary and secondary.

The replacement of the VTs indicated in the previous paragraph must be foreseen and described in the installation manual of these "AUX" units.

7.8.5 Auxiliary services protection module.

Above the "transformer protection unit" there will be an "auxiliary services protection module" that must be easily accessible from the front of the "AUX" unit and that will not interfere with any other functional element of the switchgear.

The auxiliary services protection module must be compliant with the standards EN 61439-2 and EN 61439-1, and will have, as a whole and in service conditions, the following electrical characteristics:

- Rated frequency (f_n): 50 Hz.

Technical Specification code: GRI-GRI-MAT-E&C-0002

Version no.3 dated 03/10/2022

Subject: Enel Grids - GSM001 - Medium Voltage Gas Insulated Switchgears for secondary distribution substations

Application Areas

Perimeter: Global

Staff Function: -

Service Function: -

Business Line: Enel Grids

- Rated insulation voltage (U_i): 500V.
- Rated operational voltage (U_e): 400V.
- Rated impulse withstand voltage (U_{imp}): 6kV
- Rated current (I_n): 5A
- Rated conditional short-circuit current (I_{cc}): 10kA

The output of the voltage transformer will be wired up to this module, where a general protection device and a specific protection device for each output circuit will be installed. In case of voltage transformers with double tap secondary winding, intended to connect alternatively their primary to two different nominal network voltage while maintaining 230V output, a switch will also be installed in this module with which to select the network voltage.

The auxiliary circuits that are powered from this module and that must be individually protected are:

- Remote-control power supply circuit.
- Lighting circuit.
- Power supply circuit for the ferroresonance damping resistor.

The protection devices installed to implement a general protection and an individual protection for each circuit will be the following:

- 1 fuse holder for general protection, from which all the auxiliary circuits will derive. Size 10x38, 2P in the case of "AUX" units intended for a single network voltage and 3P in the case of "AUX" units intended for two network voltages, with fuses $I_n=2A$ gG, $U_e \geq 400V$ and breaking capacity $\geq 50kA$. With on load switching capacity.
- 1 bipolar (2P) circuit-breaker to protect the remote-control power supply circuit. With both poles protected, $I_n = 1.5A$, $U_n \geq 400V$, curve C, with breaking capacity $I_{cn} \geq 6kA$ according to EN 60898-1 and $I_{cu} \geq 10kA$ according to EN 60947-2.
- 1 bipolar (2P) circuit-breaker to protect the lighting circuit. With both poles protected, $I_n = 1A$, $U_n \geq 400V$, curve C, with breaking capacity $I_{cn} \geq 6kA$ according to EN 60898-1 and $I_{cu} \geq 10kA$ according to EN 60947-2.
- 1 bipolar (2P) circuit-breaker to protect the power supply circuit for the ferroresonance damping resistor. With both poles protected, $I_n = 1A$, $U_n \geq 400V$, curve C, with breaking capacity

Technical Specification code: GRI-GRI-MAT-E&C-0002

Version no.3 dated 03/10/2022

Subject: Enel Grids - GSM001 - Medium Voltage Gas Insulated Switchgears for secondary distribution substations

Application Areas

Perimeter: Global

Staff Function: -

Service Function: -

Business Line: Enel Grids

$I_{cn} \geq 6kA$ according to EN 60898-1 and $I_{cu} \geq 10kA$ according to EN 60947-2. This switch shall incorporate an auxiliary contact to allow remote signaling of its status.

The “auxiliary services protection module” must have a degree of protection IP 2X according to standard EN 60529 and IK 08 according to standard EN 62262.

The protection devices of the different circuits must be able to be reset with the “AUX” unit in service, maintaining in all cases the indicated degrees of protection, and must be protected by a transparent hinged cover that allows their status to be always visualized.

On the other hand, the network voltage selector, if any, shall also be operable with the “AUX” unit in service and maintaining the indicated degree of protection, but shall be independently protected by a transparent hinged cover that allows the selected network voltage to be always visible. This cover must have its closure secured by screws, so that it cannot be accessed by mistake or accidentally. The “AUX” units must always be delivered with the voltage selector, if any, positioned at the point corresponding to the highest network voltage. The network voltage selector shall be compliant with the standard EN 60947-3, and shall have $U_i \geq 400V$, $I_{th} \geq 10A$ and $I_{cc} \geq 10kA$.

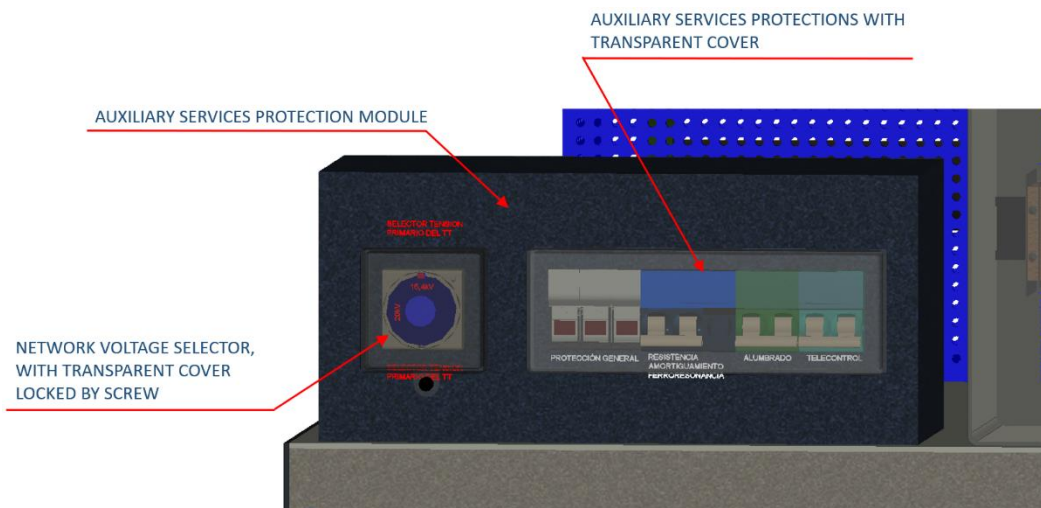

Figure 48 - Example of auxiliary services protection module in normal operating conditions

Technical Specification code: GRI-GRI-MAT-E&C-0002

Version no.3 dated 03/10/2022

Subject: Enel Grids - GSM001 - Medium Voltage Gas Insulated Switchgears for secondary distribution substations

Application Areas

Perimeter: Global

Staff Function: -

Service Function: -

Business Line: Enel Grids

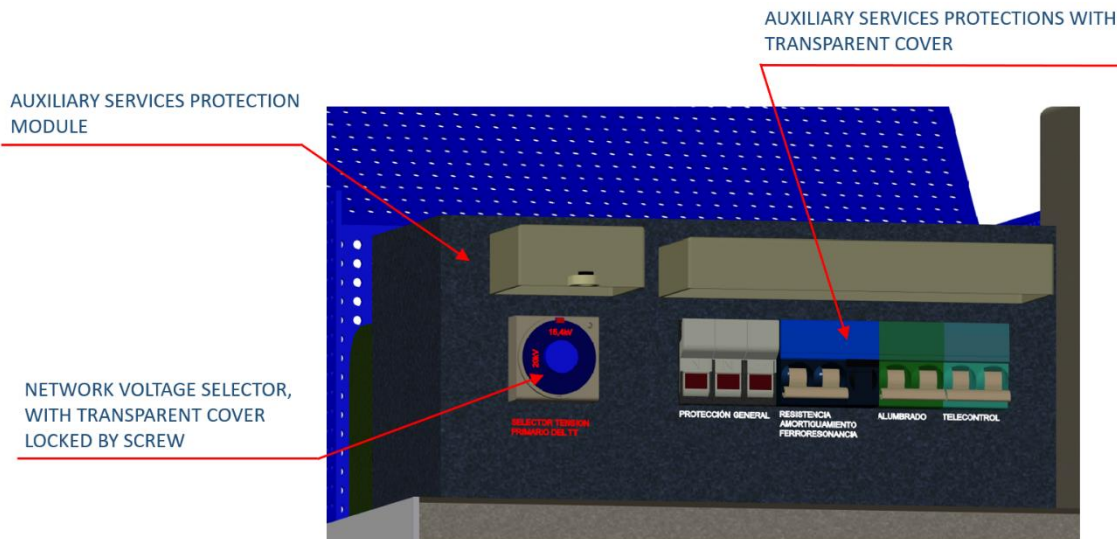

Figure 49 - Example of auxiliary services protection module with open access covers

The protection devices shall be clearly identified with the labelling corresponding to the circuit to which they belong and, likewise, the network voltage selector shall be identified, and the available voltages shall be clearly labelled. Such labelling shall be durable and visible when the switchgear is in operation.

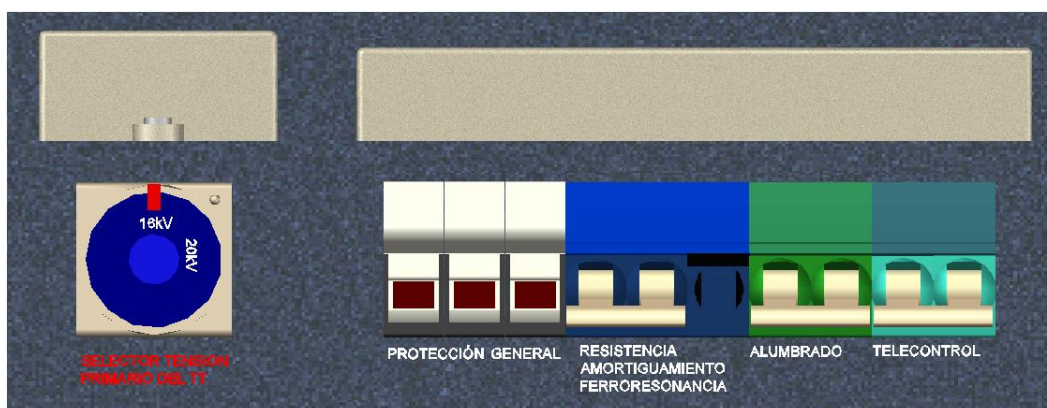

Figure 50 - Labelling of auxiliary services protections.

The wiring diagram of the assembly shall be in accordance with Figure 54 and Figure 55

7.8.6 Auxiliary services connection module.

Above the "transformer protection unit", and next to the "auxiliary services protection module" there shall be an "auxiliary services connection module" that shall be easily accessible from the front of the

Technical Specification code: GRI-GRI-MAT-E&C-0002

Version no.3 dated 03/10/2022

Subject: Enel Grids - GSM001 - Medium Voltage Gas Insulated Switchgears for secondary distribution substations

Application Areas

Perimeter: Global

Staff Function: -

Service Function: -

Business Line: Enel Grids

switchgear, through a front panel as an access door, which does not interfere with any another functional element of the assembly. Inside this module, once all the protection devices of the "auxiliary services protection module " have been disconnected, there must not be any live parts.

The "auxiliary services connection module" must be compliant with the standards EN 61439-2 and EN 61439-1, and shall have, as a whole and in service conditions, the same electrical characteristics defined for the "auxiliary services protection module". Both modules shall be considered, in relation to the requirements of these standards, as two modules forming part of the same low voltage assembly.

Fixed on a 35mm x 7.5mm symmetrical DIN rail, there shall be the following terminal blocks:

- X1.1/X1.2 → Auxiliary contacts for signaling the status of the "transformer protection unit" switch-disconnector.
- X1.3/X1.4 → Auxiliary contacts for signaling the status of the circuit-breaker that protects the ferroresonance damping resistor.
- X2.1/X2.2 → Power supply for Ferroresonance damping resistor.
- X2.3/X2.4 → Power supply for lighting circuit.
- X2.5/X2.6 → Power supply for remote control circuit.

All connection terminals shall be able to accept cable cross-sections of 2.5mm² and shall be clearly identified in a lasting way over time. The identification marks shall be clearly visible when the module is open.

The "auxiliary services connection module" must have a degree of protection IP 2X according to standard EN 60529 and IK 08 according to standard EN 62262.

In addition to the connections already made in the factory between the "Auxiliary services protection module" and the "Auxiliary services connection module", as well as the connection of the auxiliary micro-switch that shows the open position of the "Transformer protection unit" switch-disconnector, and the connection of the ferroresonance damping resistor, this module shall be equipped with two sets of fittings, provided for the connection of the different flexible tubing conduit through which the auxiliary circuits starting from the "AUX" unit will be installed. To facilitate the installation of the auxiliary circuits in any distribution of equipment that may occur in the secondary substation, there shall be a set of fittings on each side of the module, so that the different circuits can access the right or left side of the AUX unit without interfering with any functional element of the switchgear.

Technical Specification code: GRI-GRI-MAT-E&C-0002

Version no.3 dated 03/10/2022

Subject: Enel Grids - GSM001 - Medium Voltage Gas Insulated Switchgears for secondary distribution substations

Application Areas

Perimeter: Global

Staff Function: -

Service Function: -

Business Line: Enel Grids

Each set shall be made up of 4 connection fittings for 20mm diameter flexible tubing conduit. These fittings shall be quick-connect, self-adjusting (“cuttable” rubber cones shall not be allowed) and must guarantee the IP degree of the assembly both before and after the connection of the corresponding tubes.

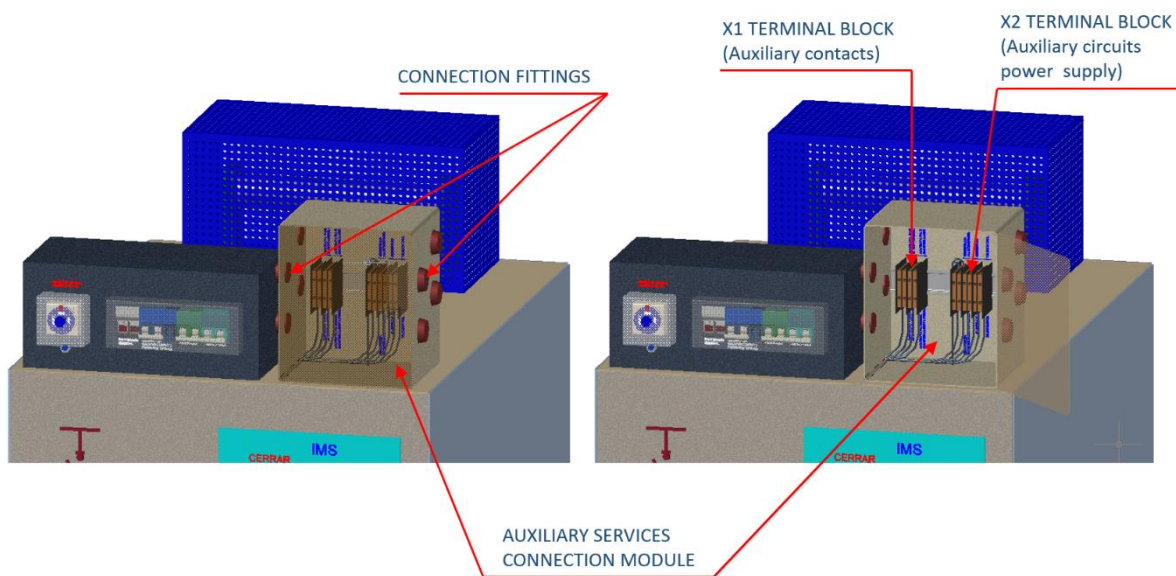

Figure 51 - Example of auxiliary services connection module

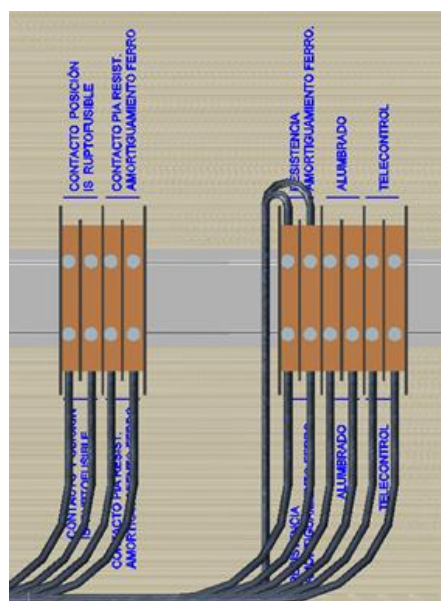

Figure 52 - Marking of auxiliary services connections

**Technical Specification code: GRI-GRI-MAT-E&C-0002**

Version no.3 dated 03/10/2022

Subject: Enel Grids - GSM001 - Medium Voltage Gas Insulated Switchgears for secondary distribution substations**Application Areas**

Perimeter: Global

Staff Function: -

Service Function: -

Business Line: Enel Grids

7.8.7 Ferroresonance damping resistor

To minimize the risk of destruction of the voltage transformer due to the occurrence of ferroresonant phenomena, the AUX unit shall incorporate a damping resistor which shall be connected to the secondary of that transformer. This connection shall be made in the "auxiliary services connection module" as shown in the diagrams in Figure 54 and Figure 55, by means of a circuit specifically designed for this purpose, protected by a circuit breaker installed in the "Auxiliary services protection module". This circuit breaker shall be associated with an auxiliary contact for signaling its position by means of an external remote-control system.

The resistor shall be located in an enclosed, naturally ventilated, dedicated module at the top of the "AUX" unit, far enough from the front to avoid accidental contact with hot surfaces but accessible in case replacement is necessary, for which the enclosure shall be fully or partially removable. It must be possible to replace the resistor without having to manipulate any other part of the switchgear.

The module containing the damping resistor must have a degree of protection IP 2X according to standard EN 60529 and IK 08 according to standard EN 62262, and its outer surface must not exceed a heating of 30K in service conditions.

This module, which is considered part of the same low voltage assembly as the "auxiliary services protection module" and the "auxiliary services connection module", must comply with the UNE-EN 61439-2 and UNE-EN 61439-1 standards.

The damping resistor must generate a power consumption, under normal operating conditions, between 10% and 13% of the heating power offered by the voltage transformer and must be able to thermally withstand the transient over-voltages that could appear when approaching the system to ferroresonant situations.

Technical Specification code: GRI-GRI-MAT-E&C-0002

Version no.3 dated 03/10/2022

Subject: Enel Grids - GSM001 - Medium Voltage Gas Insulated Switchgears for secondary distribution substations**Application Areas**

Perimeter: Global

Staff Function: -

Service Function: -

Business Line: Enel Grids

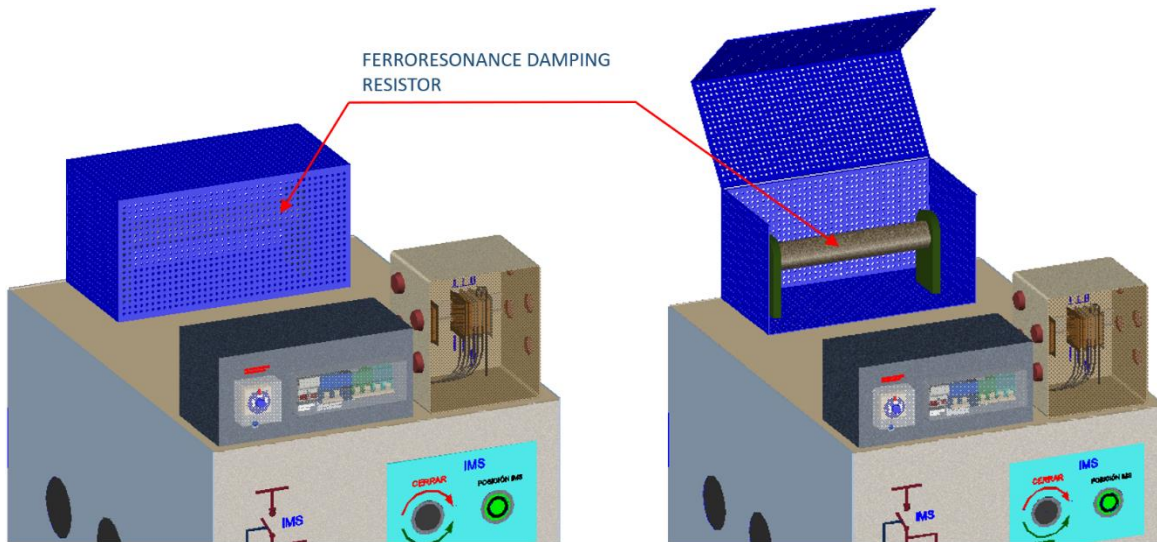
**Figure 53 - Example of module for ferroresonance damping resistor**

Technical Specification code: GRI-GRI-MAT-E&C-0002

Version no.3 dated 03/10/2022

Subject: Enel Grids - GSM001 - Medium Voltage Gas Insulated Switchgears for secondary distribution substations

Application Areas

Perimeter: Global

Staff Function: -

Service Function: -

Business Line: Enel Grids

7.8.8 Wiring diagram of the “AUX UNIT”

Figure 54 - Wiring diagram of the “AUX” units provided for a single network voltage.



Technical Specification code: GRI-GRI-MAT-E&C-0002

Version no.3 dated 03/10/2022

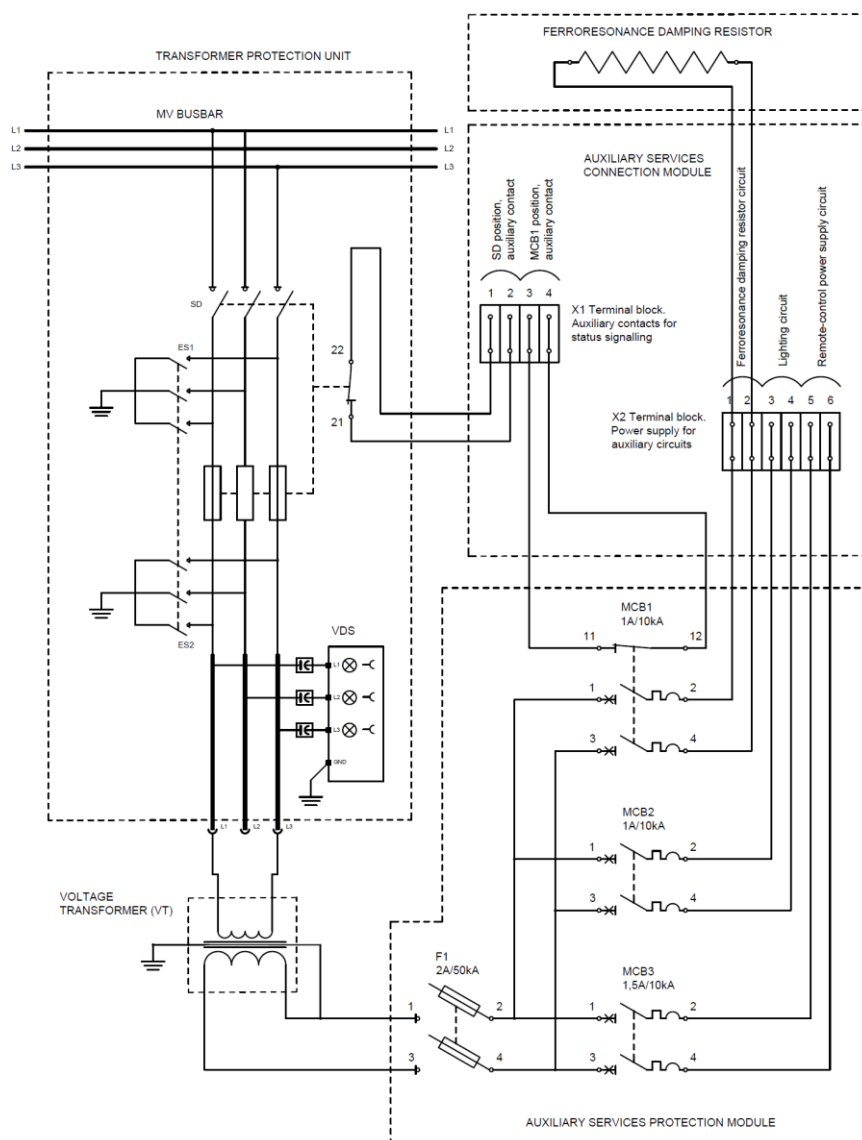
Subject: Enel Grids - GSM001 - Medium Voltage Gas Insulated Switchgears for secondary distribution substations

Application Areas

Perimeter: Global

Staff Function: -

Service Function: -

Business Line: Enel Grids

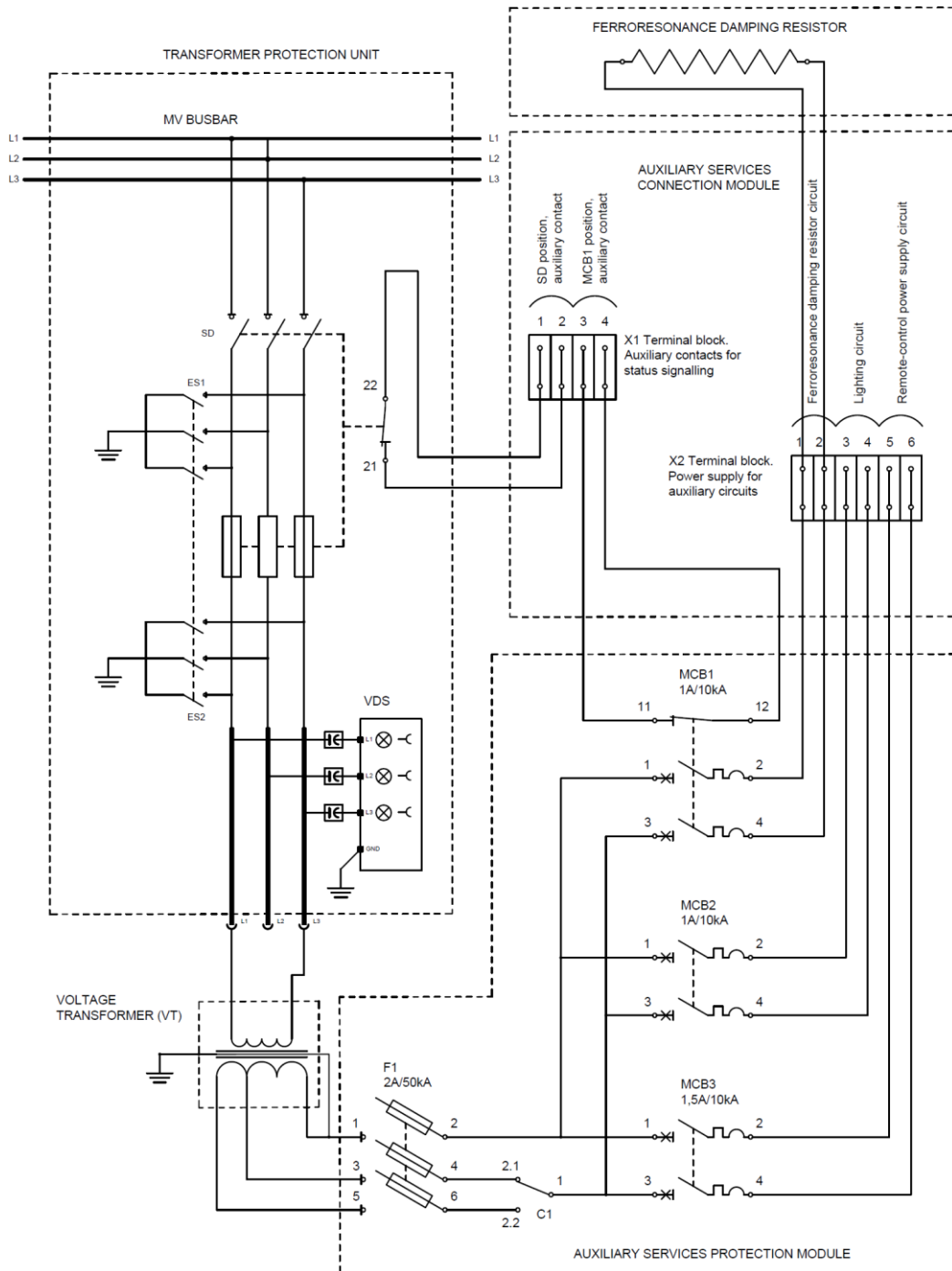

Figure 55 - Wiring diagram of the "AUX" units provided for two network voltages

Technical Specification code: GRI-GRI-MAT-E&C-0002

Version no.3 dated 03/10/2022

Subject: Enel Grids - GSM001 - Medium Voltage Gas Insulated Switchgears for secondary distribution substations

Application Areas

Perimeter: Global

Staff Function: -

Service Function: -

Business Line: Enel Grids

7.8.9 Tests.

In addition to the tests required for the transformer protection unit , the following tests shall be performed:

- The voltage transformer shall pass all the tests required by the standards EN 61869-1 and EN 61869-13.
- The cables used to connect the voltage transformer must pass all the tests required by the standard GSC001.
- The separable connectors used to connect the voltage transformer must pass all the tests required by the standard GSCC006.
- The assembly formed by the "auxiliary services protection module", the "auxiliary services connection module" and the "ferroresonance damping resistor module" must pass all the tests required by the standards EN 61439-2 and EN 61439-1.
- The "AUX" unit must pass a complementary internal arc test that guarantees that any fault in the primary of the voltage transformer is cleared by the fuses, keeping it isolated from the power system, without material being projected outside the cable compartment.

For the validation of the Ur=36kV "AUX" unit with 11kV primary VT, the same unit incorporating a 25kV primary voltage VT must have been previously validated, including this test.

The test shall be carried out in the following sequence:

Prepare the AUX unit under test, with the voltage transformer incorporated in the operating conditions of the assembly, as required in "point 6.106" and "annex AA" of the EN 62271-200 Standard for the internal arc test.

To carry out this test, the situation must be reproduced in which the energy that the power supply system can deliver to the voltage transformer, in the event of a fault, is the maximum foreseeable, so the "AUX" unit shall be equipped with the following fuses:

- Ur = 245kV switchgears → In = 100A fuses
- Ur = 36kV switchgears → In = 63A fuses
- The secondary terminals of the VT should be short-circuited with a conductor of suitable cross-section. In turn, terminal "b" should be grounded in all cases.
- Arrange the indicators as required in "Annex AA" of Standard EN 62271-200 for the internal arc test.

Technical Specification code: GRI-GRI-MAT-E&C-0002

Version no.3 dated 03/10/2022

Subject: Enel Grids - GSM001 - Medium Voltage Gas Insulated Switchgears for secondary distribution substations

Application Areas

Perimeter: Global

Staff Function: -

Service Function: -

Business Line: Enel Grids

- Adjust the power supply system to be able to provide 16kA or 20kA for 1 second (according to the rated arc fault current of the switchgear). Lower power supply systems may be used, but in this case the test results will be considered acceptable only if the maximum recorded fault currents are below the system limits, that is, if it can be verified that the power of the supply system has not limited the fault currents during the test.
- Enable the power supply system to obtain a minimum TTR value of 41kV for $U_r=24\text{kV}$, or 62kV for $U_r=36\text{kV}$.
- Supply the primary circuit to the "Um" of the VT (17.5kV, 24kV or 36kV) by means of copper cables with a minimum section of 25mm², maintaining the test parameters as indicated in point AA.4 of "Annex AA" of the Standard EN 62271-200 and with a supply circuit as indicated in point AA.5.1 of the same annex.
- Wait until an internal fault occurs in the primary circuit of the voltage transformer and the switchgear MV fuses blow.
- After the fuses blow, the power supply system will remain connected for 30 minutes.

The test layout shall correspond to that shown in Figure 56

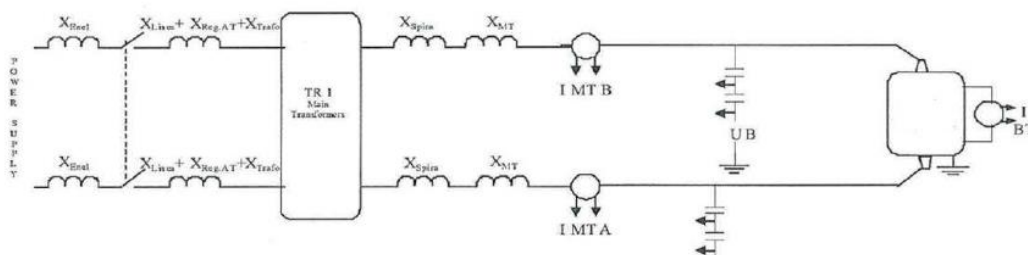

Figure 56 - Circuit for arc test in voltage transformer primary.

The test shall be considered passed if the following points are met after completion:

- Check that the power supply system has not limited the recorded fault currents (in case the power supply system is not able to provide 16kA/1s or 20kA/1s, depending on the rated arc fault current of the switchgear).
- The MV fuses have blown correctly, and the switch disconnector of the transformer protection unit has been opened by the action of the mechanical striker, leaving the fault in the cable compartment isolated from the power supply circuit.

**Technical Specification code: GRI-GRI-MAT-E&C-0002**

Version no.3 dated 03/10/2022

Subject: Enel Grids - GSM001 - Medium Voltage Gas Insulated Switchgears for secondary distribution substations**Application Areas**

Perimeter: Global

Staff Function: -

Service Function: -

Business Line: Enel Grids

-
- The requirements of "point 6.106.5" of Standard EN 62271-200 for the internal arc test are met.
 - There are no projections of fragments of the VT, or of any other element existing in the cable compartment, to the outside of that compartment.
 - The "AUX" unit remains in safe operating conditions, its protection degree (IP degree) not being altered, and the SF6 tank not having been significantly affected. Both the switch disconnecter and the earthing switches operate normally.



Technical Specification code: GRI-GRI-MAT-E&C-0002

Version no.3 dated 03/10/2022

Subject: Enel Grids - GSM001 - Medium Voltage Gas Insulated Switchgears for secondary distribution substations

Application Areas

Perimeter: Global

Staff Function: -

Service Function: -

Business Line: Enel Grids

7.9.1 Electrical construction characteristics:

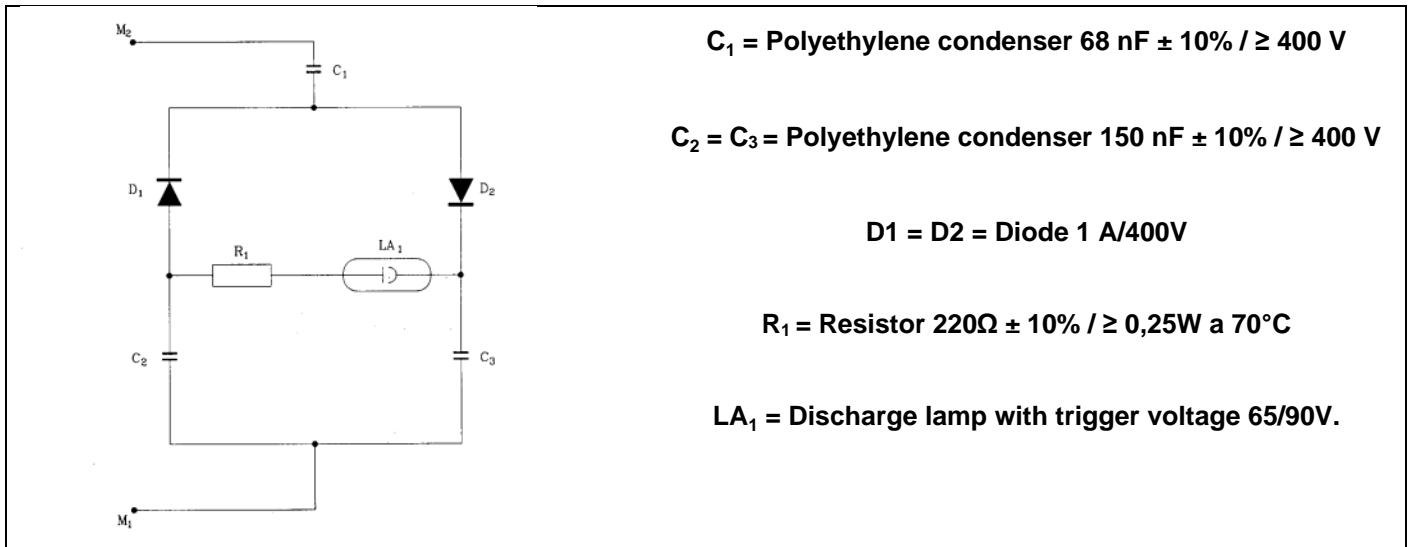

Figure 58 – Electrical Diagram

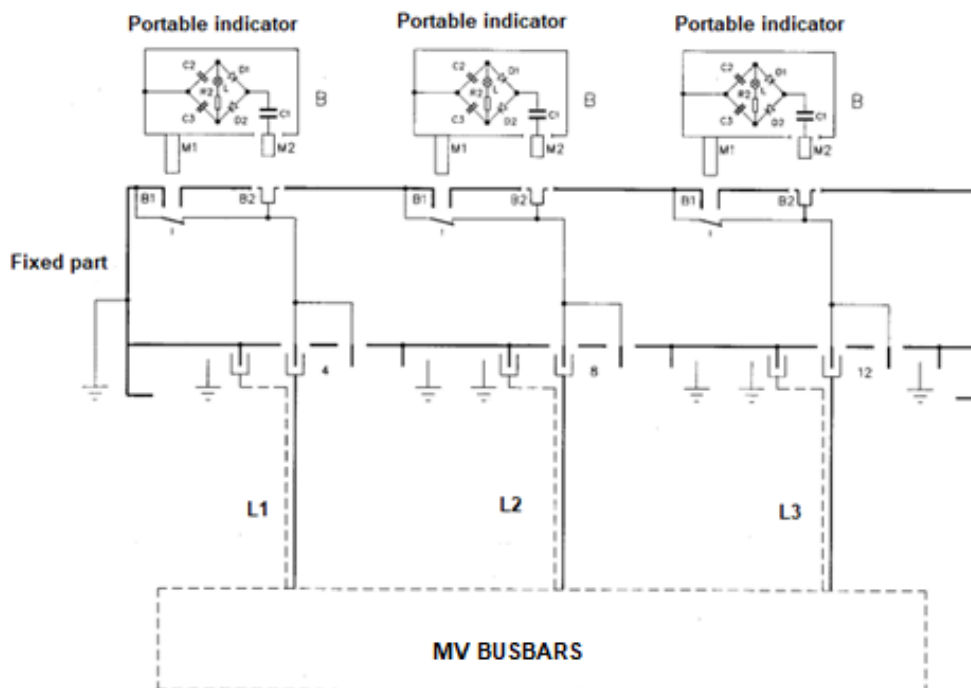

Figure 59 – Operating principle scheme

Technical Specification code: GRI-GRI-MAT-E&C-0002

Version no.3 dated 03/10/2022

Subject: Enel Grids - GSM001 - Medium Voltage Gas Insulated Switchgears for secondary distribution substations

Application Areas

Perimeter: Global

Staff Function: -

Service Function: -

Business Line: Enel Grids

7.9.2 Testing

The busbar VDS equipped with capacitive voltage dividers shall be tested as indicated herein this paragraph.

Before carrying out the tests, any capacitive divider conductor on the terminals shall be connected to the earth of the switchgear.

The following tests shall be carried out:

7.9.2.1 Measurement of the short-circuit current value.

The short-circuit current value of the capacitive voltage divider shall not exceed 500 μA when applying phase-to-phase voltage same as 24 kV. For the measurement of this current, it is necessary to remove the capacitor C_z , if any, (See Figure 60) and to proceed indirectly by measuring the voltage drop, with a voltmeter of internal impedance $Z_i \geq 20 \text{ M}\Omega$, on a given capacitive reactance of 0,96 $\text{M}\Omega$ (3,3 nF) connected between the two female fastened connections of the capacitive divider under test.

7.9.2.2 I_m current measurement.

Using the circuit of Figure 60 the I_m current values shall be measured as follows:

- a) Applying a phase-to-phase voltage same as 6,6 kV, with the switchgear de-energized, the I_m current shall be $> 2,5 \mu\text{A}$
- b) Applying a phase-to-phase voltage same as 2 kV, with the switchgear energized, the I_m current shall be $< 2,5 \mu\text{A}$
- c) Applying a phase-to-phase voltage same as 24 kV the I_m current shall be $\leq 35 \mu\text{A}$

7.9.2.3 Socket verifications

- a) Applying a phase-to-phase voltage same as 6,6 kV, with the switchgear de-energized, the "voltage present" indication shall appear ($f \geq 0,25 \text{ Hz}$)
- b) Applying a phase-to-phase voltage same as 2 kV, with the switchgear energized, the "voltage present" indication shall not appear ($f = 0 \text{ Hz}$)
- c) Applying a phase-to-phase voltage same from 2 kV up to 6,6 kV the "voltage present" indication could or could not appear ($f = 0 \text{ Hz}$)

Technical Specification code: GRI-GRI-MAT-E&C-0002

Version no.3 dated 03/10/2022

Subject: Enel Grids - GSM001 - Medium Voltage Gas Insulated Switchgears for secondary distribution substations

Application Areas

Perimeter: Global

Staff Function: -

Service Function: -

Business Line: Enel Grids

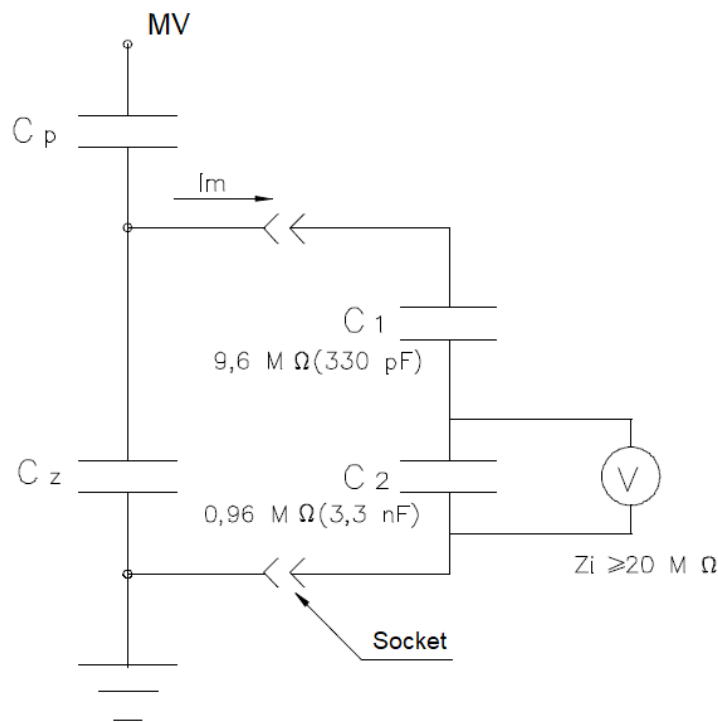
Figure 60 – Testing arrangement
7.9.2.4 Type tests

The VDS shall be tested according to IEC 61243-5 (to the extent applicable).

7.9.2.5 Acceptance tests

Test	Standard	Point
Arrangement assembly markings, instruction for use	IEC 61243-5	5.2
Dielectric strength	IEC 61243-5	5.3
Threshold voltage and input impedance of indicators	IEC 61243-5	5.15
Vibration resistance	IEC 61243-5	5.12
Clear indication	IEC 61243-5	5.11

Table 22 – Acceptance test for Busbar VDS

Technical Specification code: GRI-GRI-MAT-E&C-0002

Version no.3 dated 03/10/2022

Subject: Enel Grids - GSM001 - Medium Voltage Gas Insulated Switchgears for secondary distribution substations

Application Areas

Perimeter: Global

Staff Function: -

Service Function: -

Business Line: Enel Grids

ANNEX A – TECHNICAL CHECK-LIST FOR TENDER PROCESS

GSCM001				
Rated Voltage		[kV]	24	36
Rated insulation level	Rated short-duration power-frequency withstand voltage – Common value	[kV]	50	70
	Rated short-duration power-frequency withstand voltage – Across the isolating distance	[kV]	60	80
	Rated lightning impulse withstand voltage – Common value	[kV]	125	170
	Rated lightning impulse withstand voltage - Across the isolating distance	[kV]	145	195
Rated frequency (*)		[Hz]	50 (and 60)	
Rated normal current:				
- for busbars and lines		[A]	630	
- for transformer derivation		[A]	200	
Rated short-time withstand current		[kA]	16/20	
Rated peak withstand current		[kA]	41,6/52	
Rated duration of short-circuit		[s]	1	
Degree of protection for the whole enclosure except for the operating devices:		IP3X		
Degree of protection for the operating devices (even with the operating lever inserted)		IP2XC		
Degree of protection of the external part of the switchgear		IK08		
Internal arc test	Type of accessibility	AFL		
	Rated arc fault current	[kA]	16/20	
	Rated arc fault duration	[s]	1	
Rated supply voltage of closing and opening devices and of auxiliary circuit		[Vcc]	24V -15% +20%	
Expected operating life regarding leakage performance		40 years		
Circuit Breaker				
See GSC004				
Earthing Switch				
Rated short-time withstand current (I_k) and rated establishment short circuit current (I_{ma})		[kA]	16/20	
Rated duration of short circuit (t_k)		[s]	1	
Rated peak withstand current (I_p)		[kA]	41,6/52	
Mechanical endurance class		M0		
Electrical endurance class		E2		

Technical Specification code: GRI-GRI-MAT-E&C-0002

Version no.3 dated 03/10/2022

Subject: Enel Grids - GSM001 - Medium Voltage Gas Insulated Switchgears for secondary distribution substations

Application Areas

Perimeter: Global

Staff Function: -

Service Function: -

Business Line: Enel Grids

Switch-disconnector transformer			
Rated normal current	[A]	200	
Rated short-time withstand current	[kA]	16/20	
Rated peak withstand current	[kA]	41,6/52	
Rated duration of short-circuit	[s]	1	
Mechanical endurance class		M1	
Electrical endurance class		E3	
Earthing switches ES1 or ES			
Rated short-time withstand current	[kA]	16/20	
Rated peak withstand current	[kA]	41,6/52	
Rated short-circuit duration	[s]	1	
Mechanical endurance class		M0	
Electrical endurance class		E2	
Earthing switch ES2			
Rated short-time withstand current	[kA]	1	
Rated peak withstand current	[kA]	2,5	
Rated short-circuit duration	[s]	1	
Mechanical endurance class		M0	
Electrical endurance class		E2	

Table 23 – Check-list

Application Areas

Perimeter: Global

Staff Function: -

Service Function: -

Business Line: Enel Grids

This amendment substitutes/integrates in every single paragraph some requirements or editorial corrections.

- 2 DOCUMENT VERSION MANAGEMENT

The date of the emission of the third version is 03/10/2022

- 7.3.4.2 Line Functional Unit (L)

In the section: “*b) Earthing switch operation area*” the correct wording for the colours of the operating directions are: “

For Colombia, the position shall be displayed using the following symbols:

- *black "I" letter on green background 6017 RAL-F2 corresponding to the closed position of the **earthing switch**.*
- *black "O" letter on red background 3000 RAL-F2 corresponding to the open position of the **earthing switch**.”*

- 7.3.10 Voltage detecting systems

In Table 9 there is not the busbar VDS for Spain.

- 7.3.14 Switchgear dimensions

In Table 10 – Overall dimensions, in the column “Max Depth [mm] 36kV**”, the correct requirement shall be “**Max Depth [mm] 36kV****”

- 7.4.1 Type tests

In Table 11, Type tests for switch-disconnector (SD) shall be performed according to IEC 62271-103. Type test for Earthing switch (ES) shall be performed according to IEC 62271-102.

- 7.7.2 Electric command of the switch-disconnector

First row must be: “*The kinematic mechanism of the **switch disconnecter** must not be energy storage....*”



Technical Specification code: GRI-GRI-MAT-E&C-0002

Version no.3 dated 04/01/2023

Subject: Enel Grids - GSM001 - Medium Voltage Gas Insulated Switchgears for secondary distribution substations/ERRATA CORRIGE

Application Areas

Perimeter: Global

Staff Function: -

Service Function: -

Business Line: Enel Grids

- 7.5 SUPPLY REQUIREMENTS

The supply of the switchgears shall include the UP Cable according to GSCM014.

Application Areas

Perimeter: Global

Staff Function: -

Service Function: -

Business Line: Enel Grids

ERRATA CORRIGE#2

This amendment substitutes/integrates in every single paragraph some requirements or editorial corrections.

- 7.1. List of components

Were added following material (MATERIAL CODE; TYPE CODE; COUNTRY MATERIAL CODE; DESCRIPTION):

140987; GSM001/6; ES; MV Switchgear 2L+1T SF6 FREE 24 kV 20 kA AFL IP51 C5H GSM001/6

140986; GSM001/9; ES; MV Switchgear 3L+1T SF6 FREE 24 kV 20 kA AFL IP51 C5H GSM001/9

140980; GSM001/22; ES; MV Switchgear 2L+2T SF6 FREE 24 kV 20 kA AFL IP51 C5H GSM001/22

140985; GSM001/25; ES; MV Switchgear 3L SF6 FREE 24 kV 20 kA AFL IP51 C5H GSM001/25

140984; GSM001/31; ES; MV Switchgear 1L SF6 FREE 24 kV 20 kA AFL IP51 C5H GSM001/31

140983; GSM001/47; ES; MV Switchgear 1T SF6 FREE 24 kV 20 kA AFL IP51 C5H GSM001/47

140982; GSM001/48; ES; MV Switchgear 3L+AUX 15/20KV SF6 FREE 24 kV 20 kA AFL IP51 C5H GSM001/48

140981; GSM001/50; ES; MV Switchgear AUX 15/20KV SF6 FREE 24 kV 20 kA AFL IP51 C5H GSM001/50

- 7.3.1 Switchgear characteristics

Must be added following indication:

Test values of the MV cables after installation and for searching the faults

The voltage and current applicable values during the test after installation and for searching the faults are shown in following table:

60 kV, DC, during	15 minutes
For 12/20 kV cables → 24 kV, AC, during	10 minutes
For 18/30 kV cables → 36 kV, AC, during	10 minutes
Maximum current	50 A

Table 24 - Voltage and current applicable values during the test after installation and for searching the

Faults

Must be added following indication:

Subject: Enel Grids - GSM001 - Medium Voltage Gas Insulated Ring Main Unit for secondary distribution substations/ERRATA CORRIGE2

Application Areas

Perimeter: Global

Staff Function: -

Service Function: -

Business Line: Enel Grids

Enclosure treatment for IP51 switchgear

The enclosure shall be made of stainless steel AISI 316 and strong enough to support dynamic short circuit forces and the vibration of the switch-disconnector during operation and for transportation. Equivalent stainless steel could be proposed to ENEL approval. All enclosure surfaces shall be passivated to prevent the effects of corrosion. Special attention should be paid to the passivation of the weld beads so that they are free of rust or other impurities that affect the color of the passivation.

- 7.3.2 Rated characteristics

In Table 2, must be included “Loss of service continuity category” LSC2.

- 7.3.14 Switchgear dimensions

Max Height* is 1850mm for all functional unit, including fault detector (RGDM/RGDAT) support.

In Table 10, if total height including RGDM/RGDAT support is above 1850mm, the RMU could be delivered with fault detector support disassembled or it could be reclined. In any case, total height must be communicated to ENEL department and must be evaluated.

Only for SF6 free product, in Table 10, Max Depth [mm] 24 kV** could be increased up to 1000mm (including the free space required between the switchgear and the rear wall) and physical dimension shall not exceed 900mm.

- 7.3.4.1 Rated characteristics

In Table 3 – “Characteristics of the switch-disconnector for Lines Functional Unit”, correct wording and values are given below for Rated Breaking current (**correction in bold**):

Subject: Enel Grids - GSM001 - Medium Voltage Gas Insulated Ring Main Unit for secondary distribution substations/ERRATA CORRIGE2

Application Areas

Perimeter: Global

Staff Function: -

Service Function: -

Business Line: Enel Grids

Switch-Disconnecter				
Rated Voltage (U_r)	[kV]	24	36	
Rated normal current (I_r)	[A]	630		
Rated short-time withstand current (I_k)	[kA]	16/20		
Rated peak withstand current (I_p)	[kA]	41,6/ 52		
Rated duration of short-circuit (t_k)	[s]	1		
Mechanical endurance class		M1		
Electrical endurance class		E3		
Rated breaking current	of a mainly active load	[A]	630	
	of a no-load line (TDlc)	[A]	1,5	2
	of a no-load cable (TDcc2)	[A]	16	20
	in case of earth fault (TDef1)	[A]	48	60
	with cable-charging in case of earth fault (TDef2)	[A]	28	35

- 7.3.5.1 Rated characteristics (of Transformer functional unit)

In Table 7 – “Characteristics of the circuit breaker in transformer protection functional unit”, must be added following line:

Rated operating sequence CB for rapid auto-reclosing	O – 0,3” – CO – 15” – CO
--	--------------------------

- 7.3.9 Cable compartment

It shall be provided a metal duct with a diameter of 40 mm to connect the bottom of the compartments with the fault detector device. 3 equivalent cable ducts are accepted as well. Below an example:



Type code	Rated Voltage	Configuración	Description	Country Code Spain GSM001_Rev.0 (RGDAT V3)	Country Code Spain GSM001_Rev.>0 (RGDAT V4)
GSM001/1	24kV	2L+1T	MV Switchgear 2L+1T SF6 24 kV 16 kA AFL IP3X C3H GSM001/1	140224	141160
GSM001/2	24kV	3L+1T	MV Switchgear 3L+1T SF6 24 kV 16 kA AFL IP3X C3H GSM001/2	140226	141159
GSM001/8	24kV	2L+2T	MV Switchgear 2L+2T SF6 24 kV 16 kA AFL IP3X C3H GSM001/8	140225	141158
GSM001/10	24kV	1L	MV Switchgear 1L SF6 24 kV 16 kA AFL IP3X C3H GSM001/10	140294	141157
GSM001/16	24kV	1T	MV Switchgear 1T SF6 24 kV 16 kA AFL IP3X C3H GSM001/16	140298	141156
GSM001/17	24kV	2L+1T	MV Switchgear 2L+1T SF6 24 kV 20 kA AFL IP3X C3H GSM001/17	140483	141155
GSM001/18	24kV	3L+1T	MV Switchgear 3L+1T SF6 24 kV 20 kA AFL IP3X C3H GSM001/18	140281	141162
GSM001/19	24kV	2L+2T	MV Switchgear 2L+2T SF6 24 kV 20 kA AFL IP3X C3H GSM001/19	140280	141154
GSM001/20	24kV	3L	MV Switchgear 3L SF6 24 kV 20 kA AFL IP3X C3H GSM001/20	140282	141153
GSM001/21	24kV	1L	MV Switchgear 1L SF6 24 kV 20 kA AFL IP3X C3H GSM001/21	140478	141152
GSM001/26	24kV	1T	MV Switchgear 1T SF6 24 kV 20 kA AFL IP3X C3H GSM001/26	140255	141151
GSM001/54	24kV	3L +AUX 10/15KV V	MV Switchgear 3L+AUX 10/15KV SF6 24 kV 16 kA AFL IP3X C3H GSM001/54	140746	141141
GSM001/55	24kV	3L +AUX 15/20KV V	MV Switchgear 3L+AUX 15/20KV SF6 24 kV 16 kA AFL IP3X C3H GSM001/55	140747	141140
GSM001/56	24kV	AUX 10/15KV V	MV Switchgear AUX 10/15KV SF6 24 kV 16 kA AFL IP3X C3H GSM001/56	140750	141139
GSM001/57	24kV	AUX 15/20KV V	MV Switchgear AUX 15/20KV SF6 24 kV 16 kA AFL IP3X C3H GSM001/57	140744	141138

GSM001/58	24kV	AUX 10/15K V	MV Switchgear AUX 10/15KV SF6 24 kV 20 kA AFL IP3X C3H GSM001/58	140724	141137
GSM001/59	24kV	AUX 15/20K V	MV Switchgear AUX 15/20KV SF6 24 kV 20 kA AFL IP3X C3H GSM001/59	140722	141136
GSM001/67	24kV	3L +AUX 10/15K V	MV Switchgear 3L+AUX 10/15KV SF6 24 kV 20 kA AFL IP3X C3H GSM001/67	140717	141135
GSM001/68	24kV	3L +AUX 15/20K V	MV Switchgear 3L+AUX 15/20KV SF6 24 kV 20 kA AFL IP3X C3H GSM001/68	140718	141134
GSM001/36	36kV	2L+1T	MV Switchgear 2L+1T SF6 36 kV 20 kA AFL IP3X C3H GSM001/36	140481	141150
GSM001/37	36kV	3L+1T	MV Switchgear 3L+1T SF6 36 kV 20 kA AFL IP3X C3H GSM001/37	140292	141149
GSM001/38	36kV	2L+2T	MV Switchgear 2L+2T SF6 36 kV 20 kA AFL IP3X C3H GSM001/38	140291	141161
GSM001/39	36kV	3L	MV Switchgear 3L SF6 36 kV 20 kA AFL IP3X C3H GSM001/39	140293	141148
GSM001/40	36kV	1L	MV Switchgear 1L SF6 36 kV 20 kA AFL IP3X C3H GSM001/40	140477	141147
GSM001/45	36kV	1T	MV Switchgear 1T SF6 36 kV 20 kA AFL IP3X C3H GSM001/45	140263	141146
GSM001/64	36kV	AUX 25KV	MV Switchgear AUX 25KV SF6 36 kV 20 kA AFL IP3X C3H GSM001/64	140721	141145
GSM001/65	36kV	AUX 11KV	MV Switchgear AUX 11KV SF6 36 kV 20 kA AFL IP3X C3H GSM001/65	140723	141144
GSM001/69	36kV	3L +AUX 25KV	MV Switchgear 3L+AUX 25KV SF6 36 kV 20 kA AFL IP3X C3H GSM001/69	140719	141143
GSM001/70	36kV	3L +AUX 11KV	MV Switchgear 3L+AUX 11KV SF6 36 kV 20 kA AFL IP3X C3H GSM001/70	140720	141142

